

ELECTRONICTM

Servicing & Technology

JUNE 1988/\$2.50

The digital storage oscilloscope: Providing the competitive edge
Repair that digital DMM • Using the logic analyzer

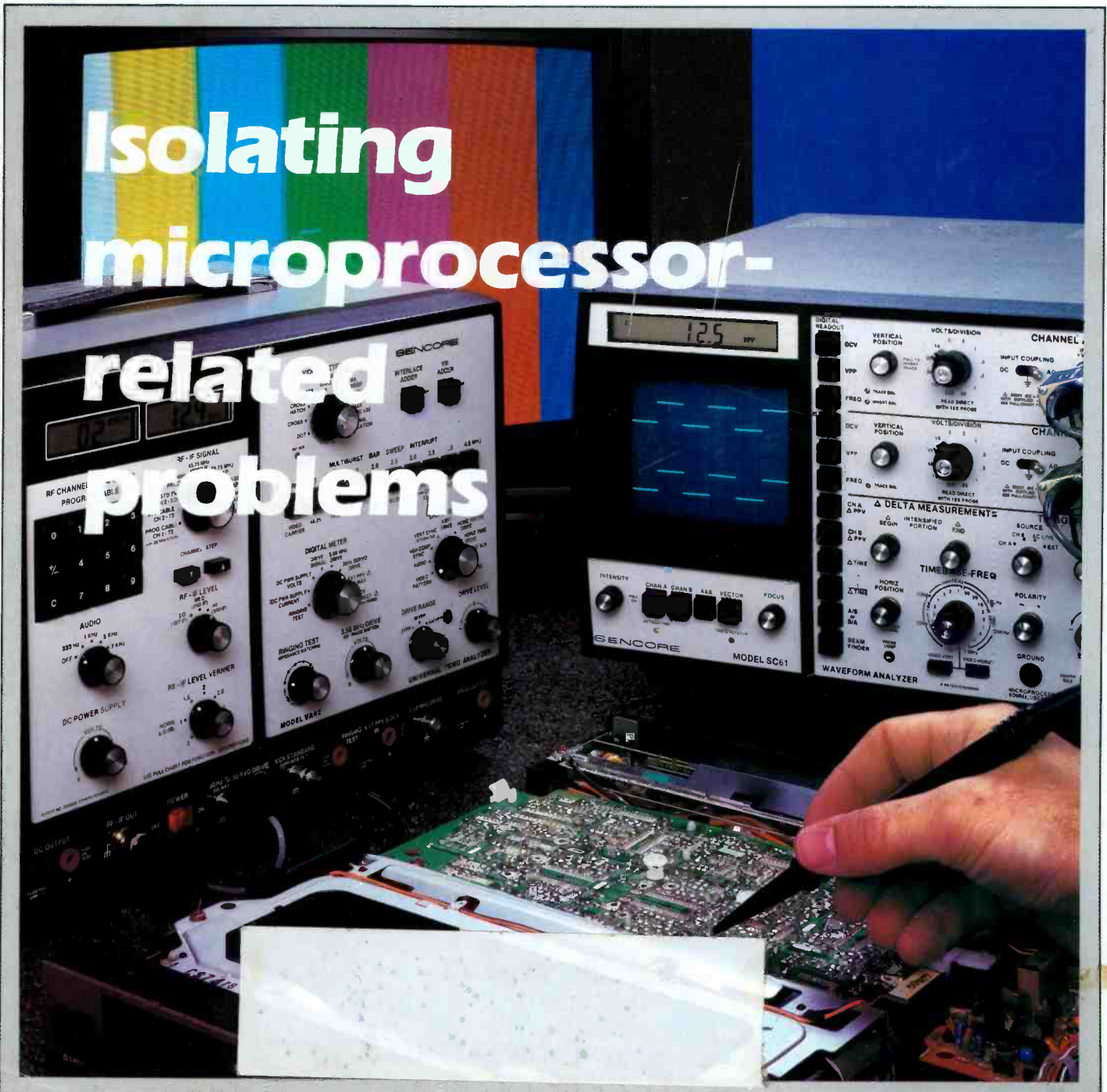

Isolating microprocessor- related problems

Intermittents. We Hear You.

Introducing The Heavy-Duty DMM With An Audible Readout That Lets You Keep Both Eyes On The Job.

Intelligent design and solid construction make the new HD 150 Series the best DMMs in their class.

They're the latest in a distinguished line that began when Beckman Industrial pioneered heavy-duty DMMs with their distinctive yellow color. Many competitors have since imitated that color. As for imitating their performance, no one comes close.

The HD 150 Series attains new levels of excellence with a range of advanced features. They're waterproof. Drop proof.

Auto-ranging. Slim-styled for one-hand comfort and convenience. With auto-off to prolong battery life. Plus 2 fuses, PTC resistor and MOV for unsurpassed overload protection.

Audible readout. A "sound" reason to go with the HD 150 Series. With this unique feature on the HD 153, you measure parameters by listening to a continuous variable tone. As the parameter you measure rises or falls, the tone's frequency increases or decreases, accordingly. Use it for volts, amps, or ohms. It's ideal for peaking and nulling, too.

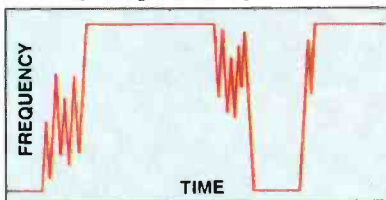

Intermittent alert. A key application of audible readout. The HD 153 pinpoints intermittents by emitting a "crackling" sound when they're detected. The response sounds in about 1 msec—far faster than the information appears on any DMM display.

Logic function.

The HD 153 detects TTL or CMOS logic pulses using standard test leads.

Easy to use.

The HD 150 Series lets you read the LCD even at wide angles. With the large rotary dial you select functions with one-handed (right or left) convenience. Auto-ranging speeds you to the right range. A tilt-stand and Skyhook let you set or hang the DMM almost anywhere.



Built tough to work hard. The HD 150 Series DMMs are so tightly sealed against water and grime that they're *guaranteed for five years* against contamination. And, because they're built so tough, they're guaranteed for two years against *any* damage (except abuse). Crashes, overloads, moisture, dust... you name it. The HD 150 Series can handle it all!

Listening is believing. For a hands-on demo, see your distributor now. Learn why the HD 150 Series is the soundest DMM value you'll see. Or hear.

Key Specifications

	HD 151	HD 152	HD 153
Auto-ranging	✓	✓	✓
Range Lock		✓	✓
Audible readout			✓
Tilt Stand and Skyhook™	Optional	Optional	Included
Logic pulse detector			✓
DC voltage accuracy	0.7%	0.5%	0.25%
10A range		✓	✓
Suggested list price	\$149.00	\$169.00	\$199.00

Beckman Industrial™

Beckman Industrial Corporation
Instrumentation Products Division
A Subsidiary of Emerson Electric Company
3883 Ruffin Road, San Diego, California 92123-1898
(619) 495-3200 • FAX: (619) 268-0172 • TLX: 249031

*In Service
Instruments,
We're The One.*

© 1988 Beckman Industrial Corporation
Specifications subject to change without notice.
Valox is a registered trademark of General Electric Corporation.

Circle (1) on Reply Card

www.americanradiohistory.com

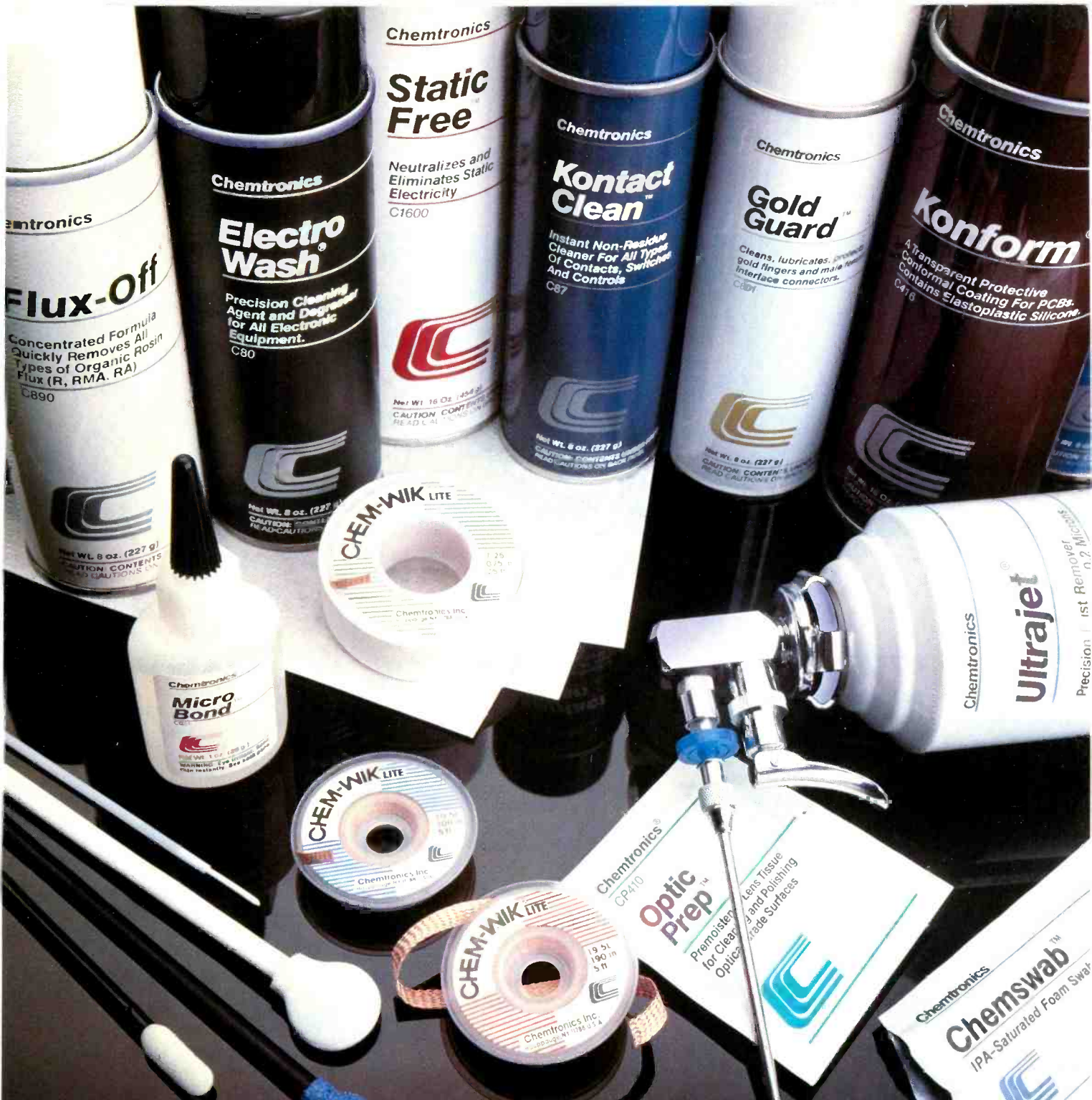

SEEK PROFESSIONAL HELP

Servicing electronic equipment isn't always easy, especially if you're doing it in the field. At Chemtronics we can help with over 200 specially engineered products for the maintenance, repair and production of high technology equipment. Call today for our latest problem solving catalog.

Circle (3) on Reply Card

Chemtronics
Keeping pace with advanced technology

Chemtronics, Inc, 681 Old Willets Path, Hauppauge, NY 11788 800-645-5244 In NY 516-582-3322 Telex 968567

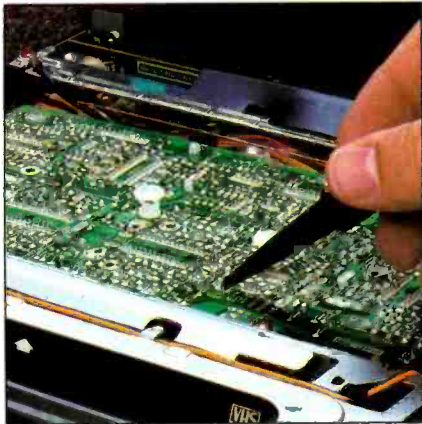

Page 8

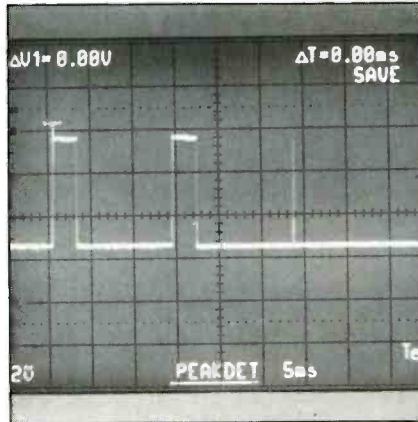

Page 20

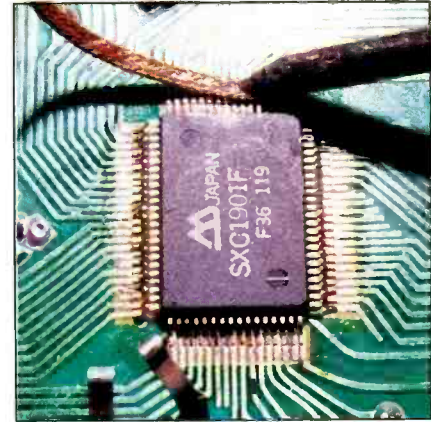

Page 42

FEATURES

8 Isolating microprocessor-related problems

By Gregory D. Carey, CET

The word *microprocessor* might sound a little intimidating, but there's really nothing spooky about tracking down microprocessor-related problems—just five easy tests will isolate most of them for you.

16 Using the logic analyzer

By David J. Blakemore

So what do you do if the symptoms you see in a malfunctioning computer point to five different potential problems? The logic analyzer is one tool that just might speed up the detective process.

20 The digital oscilloscope: Providing the competitive edge

By Brad Harris

Did you ever wait around for a transient to occur, and it was all over so quick you wished you could see the whole thing again? The digital storage oscilloscope can help you capture those pesky transients and hold them right where you want them.

42 Repair that digital DMM

By Victor Meeldijk

Is that broken multimeter really not worth repairing? If you want to try anyway, you'll need to take lots of measurements and pay close attention to detail, as this case history shows.

52 A build-it-yourself signal injector

By Gregory Lettera

Here's one of those handy little gadgets that just make servicing easier. This simple, portable multivibrator circuit is ideal for tracking down defective amplifiers in the field or on the bench.

48 What do you know about electronics?

Hall-controlled motors

54 Troubleshooting tips

56 Products

58 Syncure

60 Audio corner

Setting up a shop log—by computer

62 Computer corner

Interfacing computers to the analog world—Part I

64 Video corner

The automatic search function

66 Readers' exchange

68 Advertisers' index

DEPARTMENTS

4 Editorial

Hold that thought

6 News

18 Test your electronics knowledge

19 Literature

26 Books

28 Technology

Audiotape gets rapid transit

31 Profax

ON THE COVER

Microprocessors are a fact of life in electronics servicing. You'll find them in VCRs, microwave ovens, TVs and even your own test equipment. Still, many servicers think microprocessors are difficult to service, probably because they believe microprocessors are much more complex than they really are. If there is one golden rule to correcting possible microprocessor problems, it's *remove the microprocessor only as a last resort.* (Photo courtesy of Sencore.)

The how-to magazine of electronics...

ELECTRONIC

Servicing & Technology

LEADER

LFG-1300S
0.002 Hz-2 MHz



LBO-518
100-MHz Four Channel
Oscilloscope

LFG-131J
0.01 Hz-10 MHz



2 MHz

10 MHz

Sweep- Function Generators

Leader 10-MHz and 2-MHz Sweep-Function Generators are exceptionally durable and versatile. They have every important feature, and every required waveform including:

- Sine, square, triangle, sawtooth, ramp, pulse and TTL outputs • 1000:1 and 100:1 ranges
- Adjustable waveform symmetry • AM or FM modulation • VCO and GCV • Linear and log sweep • Plus CW, triggered, gate and burst modes (1310 only) • And lots more!

Call toll-free
(800) 645-5104
In NY State
(516) 231-6900

Request an evaluation unit, our latest Test Instrument Catalog with over 100 outstanding products, the name and address of your nearest "Select" Leader Distributor, or additional information.

For professionals
who
know
the
difference.
LEADER
Instruments Corporation

For Information Circle (4) on Reply Card
For Demonstration Circle (5) on Reply Card

380 Oser Avenue Hauppauge, New York 11788
Regional Offices: Chicago, Dallas, Los Angeles, Boston, Atlanta
In Canada call Omnitrionix Ltd. (514) 337-9500

Hold that thought

Consumer electronics servicing has changed immensely over the years. Many of you no doubt remember the early days when servicing a TV ordinarily meant attacking it with a tube tester and a box of vacuum tubes. You would use a combination of circuit knowledge, component testing and substitution to get the unit back in working order.

Although the function of TV sets has not changed much, except for the addition of color to the picture, the circuitry has evolved tremendously. From vacuum tubes we changed to transistors, then to integrated circuits. Power supplies have changed, in general, from the old, inefficient, center-tapped transformer/2-diode supply to the transformerless full-wave bridge. Now, switching power supplies are being found in more and more TVs.

And in the interest of safety, both to consumers and the TVs themselves, the sets have been outfitted with start-up and shut-down circuits.

A little reflection will show that these changes are just the highlights. A lot of changes have been made.

The results of these changes have been a combination of vastly improved reliability, far better picture quality, increased efficiency, smaller size and weight, and a manyfold increase in the difficulty of diagnosis and servicing.

But this problem is not limited to consumer electronics servicing. Almost everything in this world—from cars to airplanes and from manufacturing to weapons systems—is becoming more complex as we ask them to do more, and do it more efficiently and faster.

A problem that has always existed is made worse by this increased complexity. Where do you find someone who has the expertise to diagnose these highly complex products? To make matters worse, after you have found an expert, when he leaves, whether because of retirement, a job change or death, all of the knowledge he has accumulated over the years leaves with him.

Again, this problem is not unique to consumer electronic servicing. It's also

a problem in engineering, maintenance, medicine, law—in fact, in every skilled and learned profession in our increasingly complex world.

Fortunately, the computer, one of the factors that has contributed so much to the complexity of today's world, is also being brought to bear on this problem. A recent press release from the Diebold Group, management consultants, reports on some of the progress being made in the area of *expert systems*: computer programs that contain a combination of data and logic that are "...primarily applied to fully or partially automating the work of human 'experts' whose knowledge is difficult or impossible to capture using traditional programming tools. The key element in this area is the expert system's ability to represent knowledge as a set of decision rules, expressed in a form which is comparatively easy to code and maintain. Implementation of an expert system for end users often begins with a purchased 'shell,' which includes a 'knowledge interface' to accept the rules, and an 'inference engine' to execute their logic."

The implication of interest to consumer-electronics servicing technicians is that, in the near future, manufacturers (or independent information providers like Sams) should be able to provide computer programs that would help technicians diagnose problems in specific models of products or even in a broad spectrum of products, if the program is general enough. For those technicians who feel threatened by innovations that seem to automate diagnosis, the idea of expert systems should present no threat because the tech will still need a good degree of expertise simply to obtain and feed in enough information to operate the software.

Expert systems would seem to be one excellent way to provide the guidance and help technicians need in servicing today's complex consumer electronic products. Is anyone currently exploring this possibility?

Nile Conrad Persem



PHILIPS

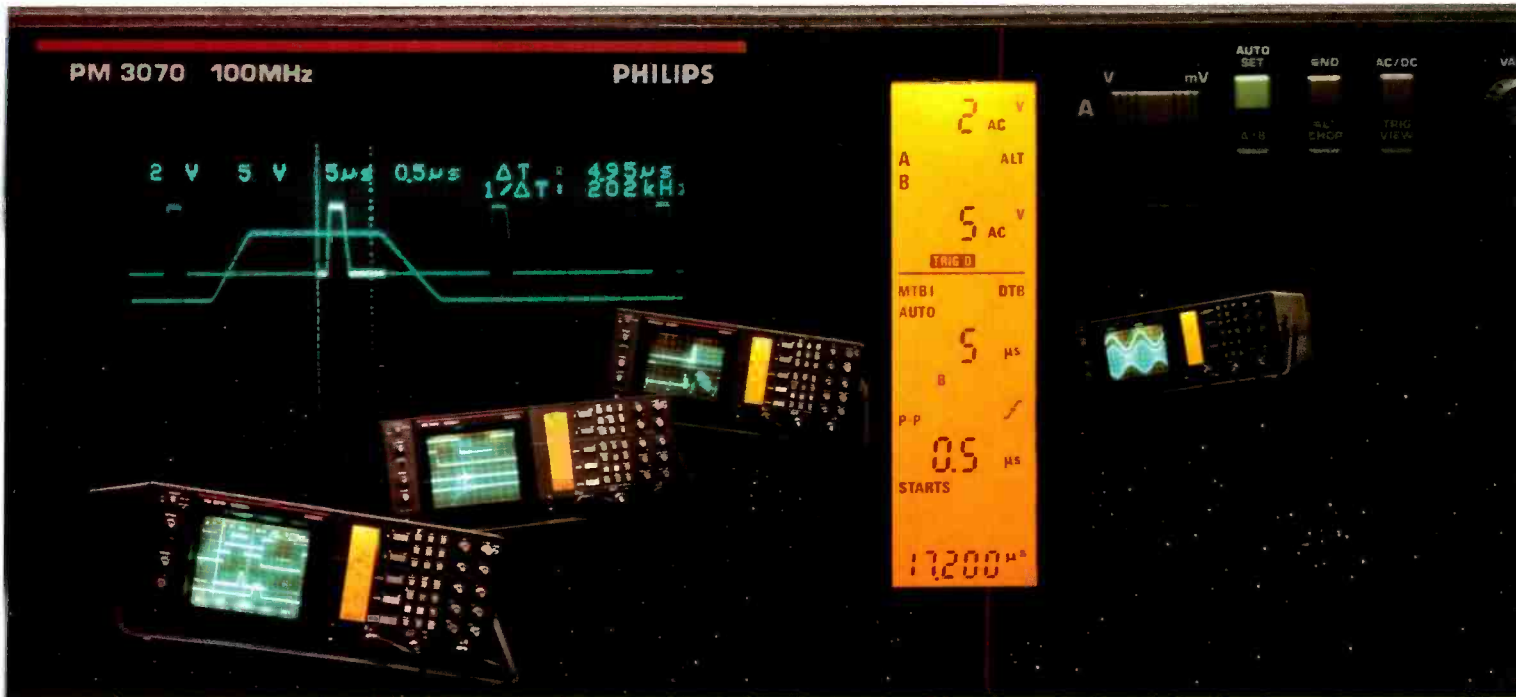

Introducing a whole new way to look at oscilloscopes.

Operation that's instinctively, unbelievably clear. Information that's detailed, yet free of errors. And intelligence that will speed your work. Philips' micro-computer controlled medium-frequency Smart Series. They could change forever the way you look at oscilloscopes.

HIGH PERFORMANCE WITH A VIEW

- **LCD window.** Large digital indications note all selected functions, instrument settings and parameter values. Instantly. Precisely. With no mistakes. And right where you need them—next to the CRT. Not hidden in crowded frontpanels. Not wasting critical waveform display area. It's a revolutionary idea that facilitates the use of an oscilloscope like nothing else. And it's only from Philips. Once again.
- **16kV CRT.** Higher acceleration voltage and advanced electron optics assure brilliance and spot quality that outshines anything else in this class.
- **Pushbutton simplicity.** Quick, one-function buttons have replaced knobs for faster, surer, more reliable operation.

- **Instant-action AUTOSET.** Philips' intelligent beamfinder automatically selects channel, amplitude, timebase and triggering for error-free display of any input signal. Great for troubleshooting!
- **"Clever" cursors and delayed sweep.** Standard on the PM 3070, "clever" cursors supply immediate amplitude and timing measurements with direct CRT readout. And an exclusive cursor-operated ZOOM function offers the most efficient use of delayed sweep available in analog scopes.
- **Auto-Triggering intelligence.** Provides fast, stable triggering up to 150 MHz.
- **Probelactor compensation in LCD.** It automatically adjusts all readouts for the probe you're using.
- **IEEE compatibility.** For fast computer hook-up and automated production test and calibration.
- **Choice of four models:** Single and dual timebase; 60 or 100 MHz bandwidths.

SUPPORTING VIEW

Philips' medium-frequency instruments come with a 3-year warranty, a 30-day money-back guarantee and all the tech-

nical and service assistance you need. From Fluke—the people who believe that extraordinary technology deserves extraordinary support.

POINT OF VIEW

Call Fluke today at **800-44-FLUKE ext. 77**. And find out how easy it is to change the way you look at oscilloscopes.

Ask for your free copy of our new guidebook, Basic Principles of Oscilloscopes.

John Fluke Mfg. Co., Inc., P.O. Box C9090, M/S 250C, Everett, WA 98206
 U.S.: 206-356-5400 CANADA: 416-890-7600
 OTHER COUNTRIES: 206-356-5500

© Copyright 1988 John Fluke Mfg. Co., Inc.
 All rights reserved. Ad No. 0481-P3065/70



SMART SERIES OSCILLOSCOPES • 60 & 100 MHz



Circle (6) on Reply Card

U.S. electronics exports up 20%

U.S. exports of electronics rose 20% in 1987 over the 1986 figure, surpassing the growth rate of electronics imports for the first time since 1980, according to the Electronic Industries Association (EIA). Total U.S. exports of electronics products totaled more than \$40 billion for 1987. Total imports, however, were almost \$57.9 billion, 15% more than the \$50.3 billion imported in 1986.

Anti-taping chip fails NBS report

The National Bureau of Standards (NBS) has released its report on the Copycode anti-taping chip. The report, which was requested by several Congressional committees studying the Copycode legislation, indicated that the chip failed each of the three major tests applied by the NBS study. According to the NBS, the system did not work as described, often failing to prevent taping and even giving false positives, which would prevent recording even when no encoding had been applied. The NBS also found that Copycode audibly distorted music and could be bypassed easily.

The report supported the objections of the Home Recording Rights Coalition (HRRC) to Congressional bills H.R. 1384 and S. 506, which would require Copycode. The report was financed by the HRRC and the recording industry, each contributing \$75,000.

Copycode works by cutting a narrow notch in the upper mid-range frequencies of music on records, tapes, discs and FM broadcasts. An anti-taping IC would also be required in DAT recorders, shutting the device down any time this notch is detected.

EIA offers surface-mount information

The Electronic Industries Association (EIA) is offering a bibliography and abstracts of more than 60 articles and publications on surface-mount technology. The articles, available through EIALINK (EIA's electronic information computer network), cover various aspects of soldering, circuit boards and inspection techniques. Hard copies will also be available.

ICCE plans technical program

The 1988 International Conference on Consumer Electronics (ICCE) will be

held in Chicago, June 8-10. The technical conference, aimed at production designers, engineers and architects of future consumer electronic products, will feature 20 technical sessions and presentations of 125 papers. Panel discussion topics will include: "Trends in New Consumer Electronic Products," "Global Standards for Advanced TV" and "Magnetic vs. Optical Storage Techniques." Educational session topics covered will include: "Advanced TV Systems," "Principles of Digital Audio," "TV Distribution Systems With an Emphasis on Cable TV," and "Flat-panel Displays."

For more information, contact the conference's sponsor, the Consumer Electronics Society of the Institute of Electrical and Electronic Engineers (IEEE), at the David Sarnoff Research Center, Princeton, NJ 08540; 609-734-2531.

EIA/CEG publish pamphlets

As part of their salute to National Consumers' Week, April 24-30, the Electronic Industries Association's Consumer Electronics Group (EIA/CEG) has announced the publication of three free consumer education pamphlets. The "Consumers Should Know" series includes pamphlets on preventive maintenance and care products; choosing accessory products; and installing audio, TV, video systems and telephones. To request a pamphlet, send a self-addressed, number 10 envelope to the EIA at P.O. Box 19100, Washington, DC 20036. On the envelope, include the name of the pamphlet and appropriate postage for each (\$0.25 for Care Products; \$0.45 for Accessory Products; \$0.65 for Hookup and Expansion).

SBCA establishes telephone hotlines

In an effort to promote home satellite-TV ownership and to educate and assist dealers and consumers, the Satellite Broadcasting and Communications Association (SBCA), assisted by General Instrument, has established two national, toll-free hotlines.

Two hotlines are available: a dealer hotline (800-356-3160) and a consumer hotline (800-533-4584). The hotlines may also be used to report (anonymously, if desired) individuals or companies involved in the manufacture, modification and sale of illegal descramblers.

ES&T

The how-to magazine of electronics

ELECTRONIC

Servicing & Technology

Electronic Servicing & Technology is the "how-to" magazine for technicians who service consumer electronics equipment. This includes service technicians, field service personnel and avid servicing enthusiasts who repair and maintain audio, video, computer and other consumer electronics equipment.

EDITORIAL

Nils Conrad Persson, *Editor*
Carl Babcoke, *Consumer Servicing Consultant*
Tom Cook, *Senior Managing Editor*
Alisa Carter, *Associate Editor*
Kathy Mickelson, *Editorial Assistant*

CONSULTING EDITORS

Homer L. Davidson, *TV Servicing Consultant*
Christopher H. Fenton, *Circuit Fabrication Consultant*
Victor Meeldijk, *Components Consultant*
Kirk G. Vistain, *Audio Consultant*
Sam Wilson, *Electronics Theory Consultant*

ART

Kevin Callahan, *Creative Director*
Barbara Miles, *Graphic Designer*

BUSINESS

Cameron Bishop, *Group Vice President*
Eric Jacobson, *Publisher*
Greg Garrison, *Sales Manager*
Stephanie Hanaway, *Promotions Manager*
Kelly Hawthorne, *Promotions Coordinator*
Dee Unger, *Advertising Business Manager*
Catherine Grawe, *Advertising Coordinator*

ADVERTISING

Regional advertising sales offices are listed in classified pages.

ADMINISTRATION

R. J. Hancock, *President*
Doug Riemer, *Circulation Vice President*
Jane J. Powell, *Circulation Director*
Jo Ann DeSmet, *Fulfillment Manager*
Barbara Clare, *Reader Correspondent*



Member, Audit Bureau of Circulation



Member, American Business Press



Member, Electronic Servicing Dealers Association

CORRESPONDENCE

Editorial, advertising and circulation correspondence should be addressed to: P.O. Box 12901, Overland Park, KS 66212-9981 (a suburb of Kansas City, MO); 913-888-4664. Home office fax: 913-888-7243. Home office telex: 42-4156 INTERTEC OLPK

SUBSCRIPTION PRICES: one year, \$19.49; two years, \$32.98 in the USA and its possessions. Foreign countries: one year, \$23.49; two years, \$36.98. Single copy price: \$2.50; back copies, \$3.00. Adjustment necessitated by subscription termination to single copy rate. Allow 6 to 8 weeks for new subscriptions.

PHOTOCOPY RIGHTS: Permission to photocopy for internal or personal use is granted by Intertec Publishing Corp. for libraries and others registered with Copyright Clearance Center (CCC), provided the base fee of \$2 per copy of article is paid directly to CCC, 21 Congress St., Salem, MA 01970. Special requests should be addressed to Eric Jacobson, publisher.

ISSN 0278-9922 \$2.00 + 0.00

INTERTEC
PUBLISHING CORPORATION

© 1988 All rights reserved.

There's so many features, You won't believe the price!

AMPROBE

Fused to 600 volts AC/DC for HIGH ENERGY PROTECTION to help protect instrument as well as user from mis-application!

- Accuracy to be found only in instruments costing much, much more
- 20 Industrial ranges: AC and DC amps, resistance and AC and DC voltage
- .1 Ω resolution - great for checking motor windings
- 1 μ A DC resolution - handy for oil burner applications
- Safety leads with replaceable lead tips
- Over-range indication
- Low battery indication
- Auto zeroes on all ranges
- Reversed polarity indication
- Accessories add 15KV AC/DC and temperature-measuring capability
- Color coded front panel with rotary switch
- Large, recessed 3½ digit LCD readout, yet a compact size and shape
- Rugged high impact molded case
- Standard banana jacks
- Battery hatch for quick and easy battery and fuse replacement

**Model
AM-12
\$44.85**



AMPROBE INSTRUMENT
DIVISION OF CORE INDUSTRIES INC. LYNBROOK, NEW YORK 11563
630 MERRICK ROAD, P.O. BOX 329
Area Code 516-593-5600 • TWX: 510225-4403 AMPROBE LYBK
ITT TLX 4971416 • EASYLINK 8288586 •
FAX 516-593-5682

**Only AMPROBE[®]
gives so much
for so little.**

Available in well over 100 Countries around the world.
Atlas Electronics in Canada.

Write for catalog AAD79 or visit your AMPROBE distributor today.

Circle (7) on Reply Card

www.americanradiohistory.com

Isolating microprocessor-related problems

By Gregory D. Carey, CET



Many technicians think microprocessors are difficult to service. Why? Probably because they think of microprocessors as computers. Yet, most microprocessors are not used as computers. They are controllers. Controllers are found in VCRs, microwave ovens, TV receivers and most microprocessor-controlled test equipment. Knowing this can make servicing microprocessors a lot less fearsome.

Let's start with a practical piece of advice: Don't change the microprocessor too quickly. Time and time again, technicians admit that changing a microprocessor doesn't help a problem that looks like it might be caused by a bad micro. Microprocessors rarely fail. They are protected from static discharge and power-line surges by buffering transistors and ICs and by filtered power supplies. The best process is to leave the micro on your list of suspects, but be sure to investigate all the other likely culprits first.

There are five quick tests you can use to isolate most microprocessor-related problems. First, you need to understand how a microprocessor used as a controller differs from one used as a computer, so that you can see why microprocessor servicing has very little to do with computer servicing.

The computer vs. the controller

The biggest difference between a microprocessor used in a computer and one used as a controller deals with programming. A computer is re-programmed every time it is used, usually by reading information from a magnetic disk or tape. The controller has only one

Carey is an application engineer at Sencore.

program, which is entered at the factory. Compared to a computer, the controller lives a relatively boring life—playing the same program over and over. Any change in the internal program is caused by some mishap, resulting in a defective microprocessor.

Computers (whether desk-top personal or large mainframes) handle large volumes of assorted data. One batch may consist of numbers for a payroll; the next may be a document from a word processor. Controllers, by comparison, receive data that are repetitive and predictable. The inputs come from

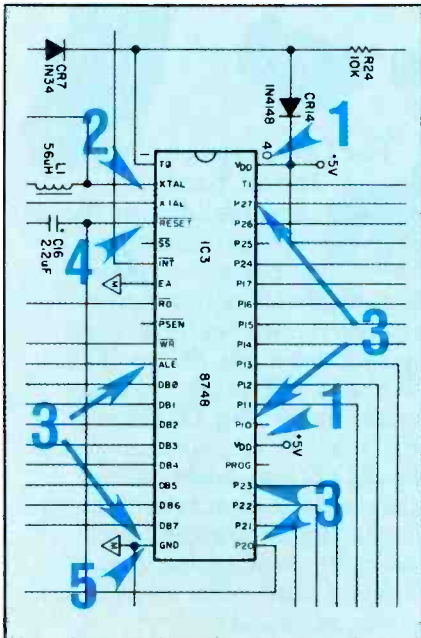

Figure 1. These five steps test the microprocessor's inputs and outputs in a logical sequence to determine whether a problem is outside the microprocessor.

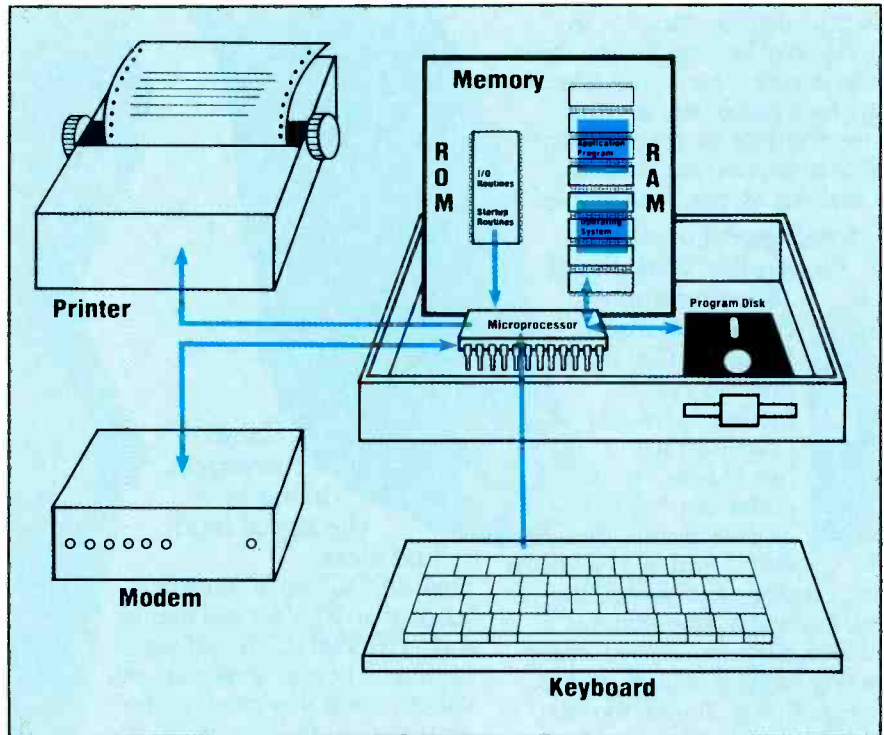

Figure 2. The microprocessor in a computer is reprogrammed every time it is turned on. It has many complex inputs and outputs, and banks of memory chips outside the microprocessor itself.

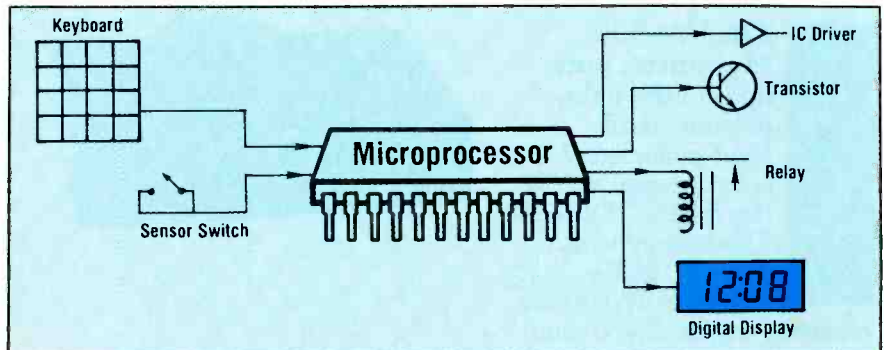

Figure 3. Most microprocessors are used as controllers, not computers. The controller has its program in permanent memory and works with simple input and output circuits.

There is choice than

No matter what specific electronic part or supplies you're looking for, the one thing you're always looking for is value. And no one else delivers it like Philips ECG. From replacement semiconductors to multimeters to audio/video test cassettes, we've got the quality you're looking for, the selection you're looking for, the value you're looking for. So if you've been hunting for a name you can trust, you're on the right track now. Philips ECG: the smartest choice you can make in electronic parts and supplies.

Intelligent Power Controller With Surge Suppression –

No smarter buy.

Philips ECG's unique
EMF-515MC

Intelligent Power
Controller has
one Master
outlet and
four electroni-
cally controlled Auxiliary



outlets. It senses when something plugged into the Master outlet is turned ON and responds by turning ON power to the Auxiliary outlets. Equipment that is plugged into the EMF-515MC is also protected from transient voltage spikes on the power line three ways: hot to neutral, hot to ground and neutral to ground.

The DM-300 Multimeter puts it all in the palm of your hand.

Most multimeters' accuracy stops at 0.5%. Not the ECG DM-300! This little dynamo delivers 0.25% accuracy! The ECG DM-300 also

has a transistor test, diode and continuity tests and is overload protected. These features and 0.25% accuracy make the DM-300 almost unbeatable!



Cable
converters
bring in
the signal loud
and clear.

Philips ECG's cable converters adapt to any TV set and receive up to 139 VHF, UHF and cable stations. They are available with volume control, separate audio and video outputs for connection to stereo and VCR systems to bring it all to you loud and clear! No matter what type of TV, Philips ECG has the converter for you.



The One Source for all Your Semiconductor Needs.

In the confusing world of electronic replacement parts, there's only one name you have to remember for all your semiconductor needs. Philips ECG. With nearly 4000 semiconductors that replace over 240,000 industry types, Philips ECG is your one source. Philips ECG's high-quality semiconductors meet most entertainment and industrial/commercial MRO replacement needs, enabling you to stock fewer parts. All of which saves you time, space and money!

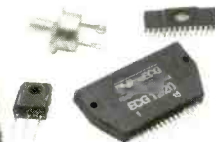

no smarter Philips ECG.



Philips ECG Time Delay Relays deliver accuracy, versatility and value.

Philips ECG time delay relays are available in several time and ampere versions for optimum versatility. Series 40 and 42 are 10 ampere relays and have a range of 0.1 seconds to 5 minutes. Series 44 and 46 are 12 ampere relays with time ranges of 0.1 seconds to 3 minutes. Repeat cycle

timers, Series 48, are also available with timing ranges from 0.1 seconds to 3.0 minutes. All have input transient protection to prohibit false triggering or damage to circuitry and are UL approved. And because Philips ECG relays replace more original relay types than any other brand, there's no smarter choice.

Philips ECG's PR-60 & PR-200: The Answer to Your Scope Probe Needs.

Whether you're an engineer, technician or a hobbyist, we've got the scope probes you're looking for. Not only in terms of features—and these models are loaded—but in terms of value. Each has switchable ground reference plus X1 and X10 attenuation for a range of applications. And each is compatible with most popular oscilloscopes. For the smart choice in scope probes, look to Philips ECG!

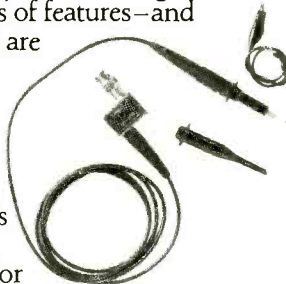

Philips ECG Chemical Products keep your Equipment up and running!

Regular maintenance is the key to maximizing the operating efficiency of all electronic equipment. Philips ECG offers a wide assortment of High Technology Chemicals that will assure optimum equipment performance. The line includes heavy duty flux remover, all-purpose degreaser, high-purity circuit refrigerant, a general contact cleaner, and a superior spray lubricant. All are available in convenient aerosol cans or in various sizes. And all are from Philips ECG, the industry leader!



You know your business. You know what you need in electronic parts and supplies. And now you know where to get them. Philips ECG. Consistent high quality you can believe in. An incredible inventory of equipment and supplies. Reliable value all up and down the line. Contact your local Philips ECG distributor or call 1-800-225-8326. It just might be the smartest call you make all day.

The Smart Choice.

Philips ECG

A North American Philips Company

Circle (8) on Reply Card

© 1988, Philips ECG

simple switches and sensors.

The microprocessor used in a computer connects to thousands or millions of bytes of external random-access memory (RAM), each byte consisting of eight memory locations. This RAM may require dozens of external memory chips. The controller only needs a small amount of memory, inside the microprocessor chip itself.

Finally, a computer has complex inputs and outputs. Inputs come from typewriter keyboards, disk drives or modems. Outputs feed printers, plotters, CRT displays or other computers. The controller only has inputs from a few switches or sensors. Its output feeds a few ICs, relays and a simple digital display.

Servicing controller-type microprocessors doesn't need to be any more complicated than servicing any integrated circuit. Because of the controller's limited environment, you don't need to know as much as you might think.

The simplified system

One of the biggest differences between servicing computers and controllers is that you don't have to worry about software problems in controllers. You don't need to know programming or ASCII codes. If you suspect a software problem, you have only one option: change the program chip.

Second, you don't have to sort through rows and rows of memory chips. This means you don't need a \$20,000 logic analyzer or an 8-channel scope to view

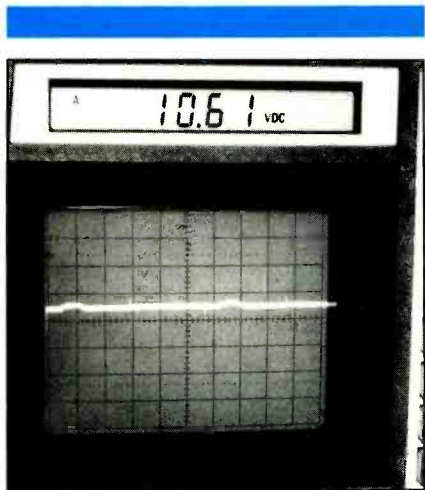

Figure 4. Check each power-supply pin for the correct dc level and for any noise or ripple. Here, the 11V supply for a CMOS microprocessor has the correct dc level and low ripple.

each byte of data separately to locate a defective memory location. If an internal memory location is defective, you have to change the microprocessor.

Finally, the controller has limited inputs and outputs, generally no more than eight of each. You can test each one separately to determine whether the problem is coming from inside the microprocessor or from an external component.

Once you stop worrying about software, memory and complicated interface systems, the microprocessor takes on a whole new look. You can find most problems by testing five standard components: the power supply, the clock, the input and output lines, the reset circuit and the grounds.

Testing the power supply

Always test the power supply(s) first, whether the problem is a totally dead



Figure 5. The clock signals must have the correct frequency and amplitude, and they must be free from glitches. This glitch causes the microprocessor to act as though it is defective.

micro or one with erratic operation. Start with the dc level. Use a digital voltmeter or the DCV function of a waveform analyzer to confirm the correct dc level. Your voltage should be within about 0.2V of the correct level.

Many microprocessors run at 5V because they use TTL logic. Some, however, may operate at voltages as high as 15V if they are the CMOS type. Be sure you check your schematic for the correct power-supply voltage.

Don't stop with dc voltage tests be-

cause noise often enters the microprocessor through the power supply, causing it to act erratically. Look at the CRT to see if the signal is clean. Measure the signal's actual value. You should see less than 0.1V of ripple.

You may see 60Hz ripple from a bad filter or regulator. You also may see

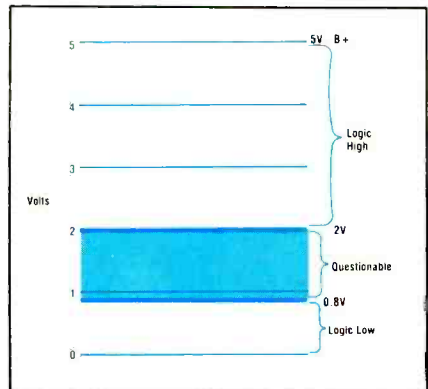

Figure 6. When testing logic inputs and outputs, remember that signals falling into the "questionable" area may cause intermittent operation.

high-frequency digital noise from a switching-type power supply or from another stage. This ripple can intermix with normal input signals. If so, suspect a bad filter choke or decoupling capacitor on the power supply line, or a bad IC on the same line that is loading the supply.

If the microprocessor has more than one power-supply pin, check each one in the same manner.

Testing the clock

A problem in the crystal-controlled clock can cause intermittent operation. Watch for the following conditions as you probe each of the microprocessor pins connected to the clock input pins. The "clock" pulses are usually generated by a crystal.

First, confirm that the clock is running at the correct frequency. The frequency must be measured to greater accuracy than is possible using a conventional oscilloscope, so you'll need a frequency counter or the frequency function of a waveform analyzer. If the frequency is incorrect, suspect a bad crystal.

Second, check the peak-to-peak amplitude of the clock output. Low amplitude may make the microprocessor miss some of the clock pulses. This makes the clock frequency seem to be

slow, even though the frequency test showed that it was correct. The results could be erratic operation of any function based on timing with another signal. Missed clock pulses caused by a low-amplitude signal could also cause the clock to keep incorrect time.

Last, use a scope CRT to examine the waveform for noise or extra "glitch" signals. These extra signals may cause the microprocessor to intermittently skip a program step, or they may cause the whole system to run too fast. The clock signal should be a clean sine or square wave.

Testing the input and output lines

Check each input pin for proper levels. Because the controller receives inputs from simple switches and circuits,



Figure 7. A toggling input or output pin may appear to be out of sync because of the changing data. Be sure that the pin is toggling and has the correct peak-to-peak level. Also, make sure the high or low levels don't fall into the questionable zone.

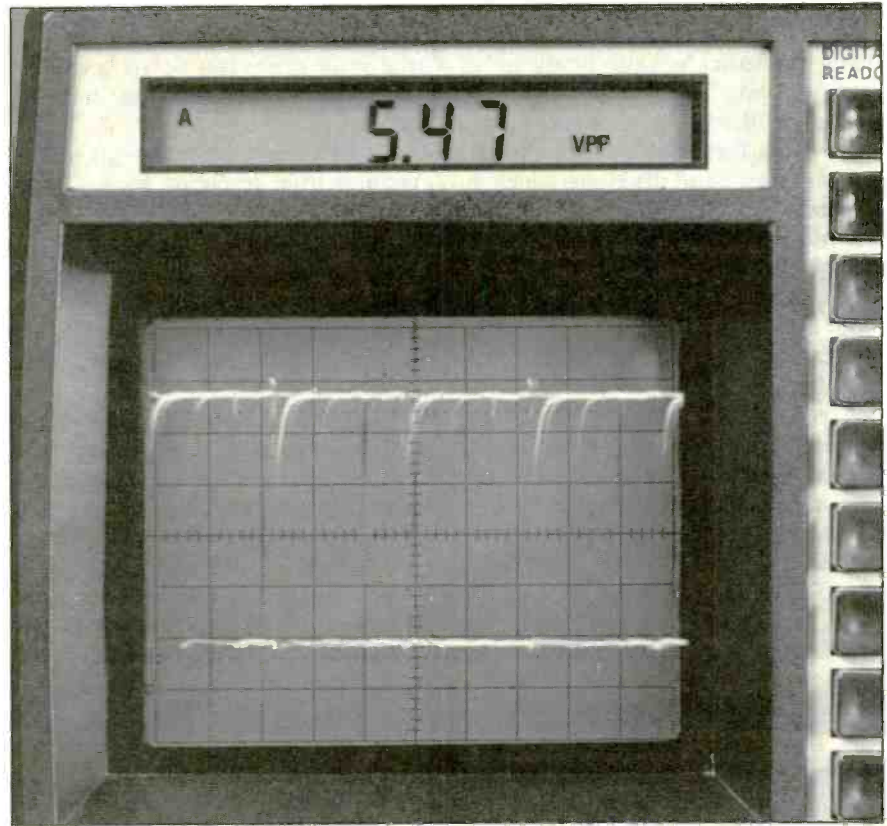

PACESETTER PRODUCTIVITY

100 MHz TEK 2246A/2245A

Smart scopes, perfect setup! Tek sets the new fast pace \$1795/\$2395 for frequent measurements with automatic front panel setup. Nonvolatile memory for up to 20 front-panel setups (2246A). Time and voltage cursors. Exclusive SmartCursors™ track waveform changes for voltage measurements. All backed by Tek's 3-year warranty.

NEW

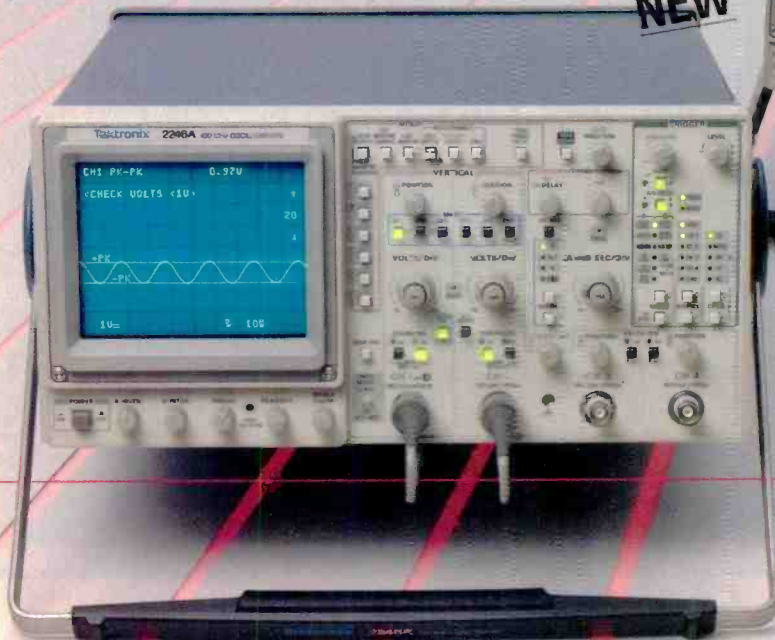

Call Tek direct
for Pacesetter specs!
1-800-426-2200

Prices subject to change without notice.

Copyright © 1988, Tektronix, Inc. All rights reserved. TTA 906-A

Tektronix
COMMITTED TO EXCELLENCE

Circle (31) on Reply Card

input problems often affect only one or two functions. Try every function controlled by the micro, and note which ones work correctly and which ones have trouble. Then, determine which input pins are associated with the bad functions. For example, one or two switches might provide an input to a single function and might not be used with any other of the micro's inputs.

Connect your scope or waveform analyzer probe to the pins associated with the questionable functions. Observe the trace as you cycle the input switches. Select dc coupling (or press the DCV button) and note the dc level with the switch contact both open and closed. Confirm that the level properly changes between the ONE and the ZERO logic level. Be sure that neither level falls into the "undefined" area between the two lev-

els, or the micro may not be able to decide whether a high or low condition exists.

Check contact resistance or pull-up resistors if the levels are wrong. Watch for noise or glitches as the contacts close. These extra signals may cause the micro to interpret a single switch operation as two or more switch closures. Check the switch contacts, decoupling capacitors and switch buffer circuits to isolate noise conditions.

Next, test all output lines to be sure one isn't stuck at logic high or logic low. Touch your probe to each microprocessor output pin, one at a time. Don't worry that the signal shows a blur of lines, which looks like an out-of-sync condition. This blur results from the asynchronous (random) data coming from the micro.

Set the scope's input coupling switch to DC to confirm that the low points on the waveform are below the minimum level for a ZERO and that the high points are above the minimum level for a ONE. Suspect a bad pull-up resistor or IC outside the micro if the signals are falling between logic levels.

If the signal at a pin remains cemented to ground or to B+, look at the schematic to see when that pin is used. You might have to trace the pin to a relay or an IC to find out which function(s) it controls. Then, press a button or cycle a sensor to force the microprocessor into a function that uses this pin.

If the signal at the pin doesn't change, the microprocessor or an external circuit may be at fault. To find out, isolate the unchanging pin from the external circuits by carefully removing the solder

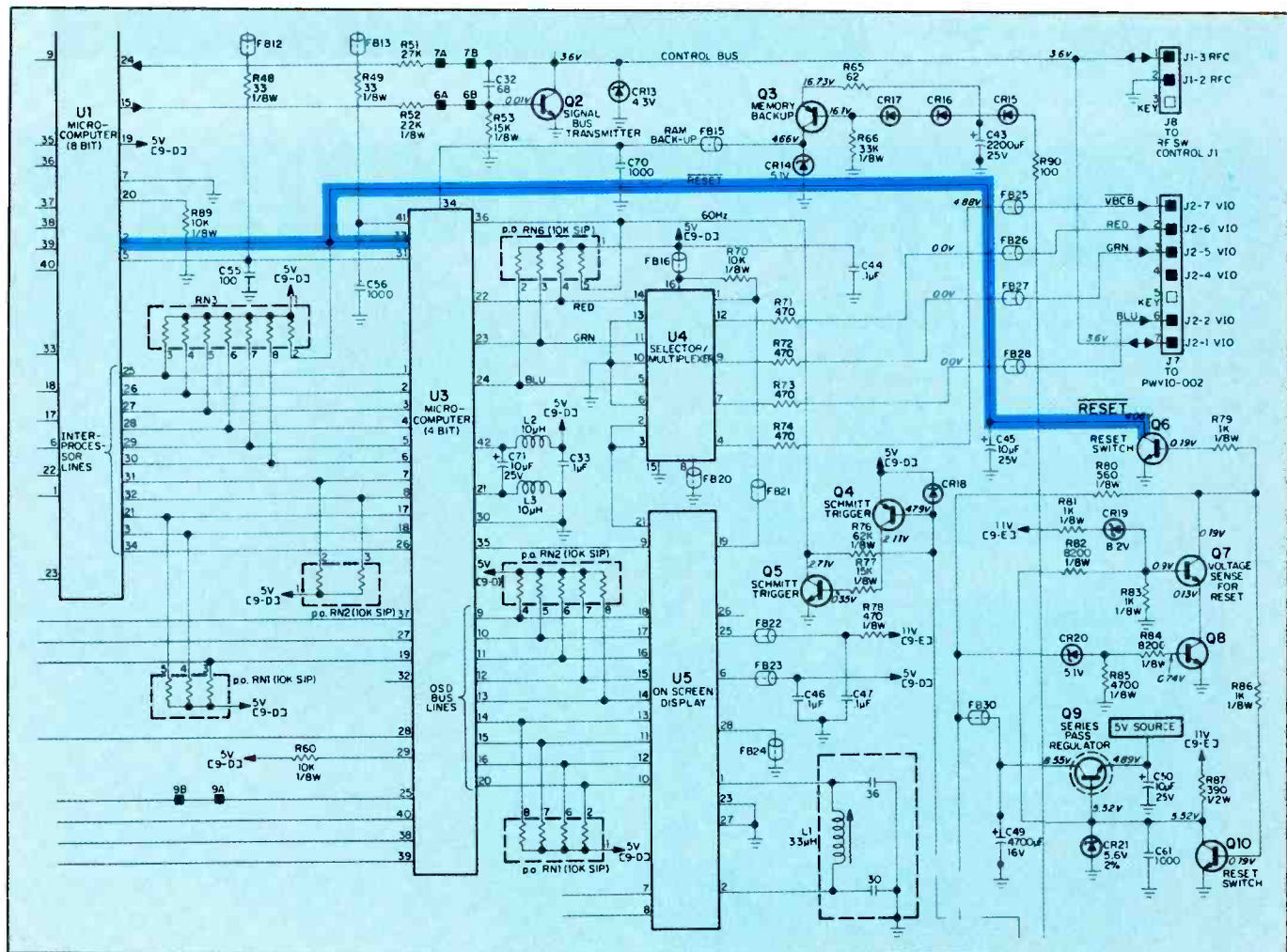

Figure 8. The reset circuits must fire when power is first applied. Here, a defective reset circuit would cause both of the tuner microprocessors to operate incorrectly.

between it and the foils on the PC board. **DON'T DESOLDER THE OTHER PINS YET.** Connect your scope probe to the isolated pin and again check for toggling. If the pin toggles with its load removed, the problem is probably outside the micro. An external component is holding the pin high or low. Isolate each component on that line, one at a time, until the line toggles. Then, replace the defective part.

If the pin remains stuck after being isolated, the problem is beginning to look more like a defective microprocessor. Don't unsolder the remaining legs, however, until you've performed the last two checks.

Testing the reset circuit

Microprocessors need an external reset pulse at turn-on. Without this reset pulse, the microprocessor starts in the middle of the program, resulting in totally unpredictable operation.

Use the CRT of your scope or waveform analyzer to check the reset pulse.

Set the trigger SOURCE switch to channel A, the trigger MODE switch to NORM and the trigger LEVEL control to the center of its rotation.

Connect the device containing the microprocessor to an ac power strip that has a switch, so that you can turn the power off and on. Don't rely on the device's power switch because the microprocessor often receives power independent of the power switch. In fact, many "power" switches are simply microprocessor inputs and don't interrupt power.

Turn off the power and connect the channel A probe to the reset pin. The CRT should show no trace because the triggering circuits are in the NORMAL mode. Watch the CRT as you apply power to the system. If you see the trace flash across the CRT, you know a reset pulse occurred and triggered the sync circuits. By watching the trace carefully, you can even measure its pulse time. The time starts at the left edge of the CRT trace (switch to the AUTO trigger-

ing mode to find its starting point) and ends when the pulse on the CRT drops. Cycle the reset circuits several times to find the pulse width. If there is no trace or if the pulse is too narrow, repair the reset circuits.

Checking grounds

If you've confirmed that all the inputs are working correctly, the microprocessor is highly suspect. But don't unsolder it yet. First, check every grounded pin. Each pin should show 0Vdc and 0Vac. If any grounded pin has a signal on it, it is floating, which will cause the microprocessor to act as though it's bad. The presence of a signal tells you there is an open in the grounded path—either a broken PC foil or a bad solder connection. Repairing the bad ground will probably clear up your trouble.

You've already confirmed that all the inputs and outputs are normal, so if the grounds are good, you are ready to substitute the micro.



PACESETTER PERFORMANCE

100 MHz TEK 2236/2235

100 MHz scope, counter, timer, DMM—just \$2795 The ultra-versatile Tek 2236 makes measuring everything from frequency, period and width to delay time and Δ time push-button easy—in addition to CRT display, you get digital readout display accurate to 0.001% and beyond. PaceSetter performance on a modest budget? Look at the 100 MHz, dual-trace Tek 2235 with the best of the basics—just \$1575!

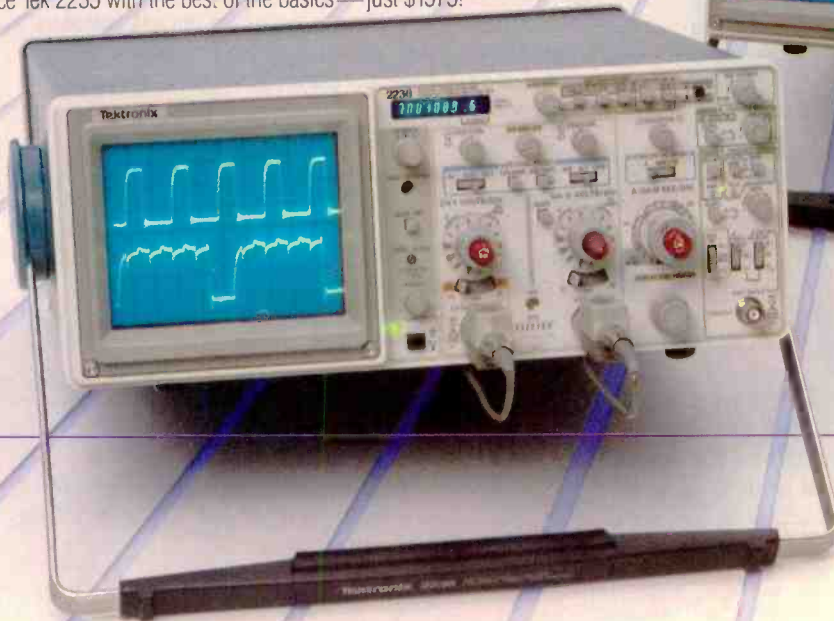

Call Tek direct
for PaceSetter specs!
1-800-426-2200

Prices subject to change without notice.
Copyright ©1988, Tektronix, Inc. All rights reserved. TTA 906-B

Tektronix
COMMITTED TO EXCELLENCE

Circle (32) on Reply Card

Using the logic analyzer

By David J. Blakemore

When a malfunctioning computer crosses your bench, the first thing you do is look at the symptoms and hope they immediately point you toward the problem. But what do you do if the symptoms point to several possible problems? Say you have a computer that turns on, spins the disk for a while, then stops. Is it the disk itself? Are the boot ROMs corrupted? Is it really running, but not listening to the keyboard or driving the CRT?

Fixing the problem isn't the hard part; the trick is finding out what the problem is. You need a tool that can help you locate the problem fast, so you can get this PC off your bench and go on to the next. One tool that can help speed up the detective process is the logic analyzer. A good analyzer is easy to use and will immediately help you find the source of the problem.

Using the analyzer

To use the logic analyzer, you simply clip its 8088 pod over the PC's microprocessor and capture some data. Again, imagine you are working on the PC with the trouble symptoms described above.

You look to see where the code is executing and find that it is "off in the weeds" (the PC is at addresses where there is no sensible code). You set a trigger word and start the analyzer again, clipping a lead on the feed to the CRT and the keyboard.

The key to a logic analyzer's usefulness is that you can set it up to stop recording at a given place and see all the data leading up to that point. One

of the most important features of an analyzer used in a servicing application is its triggering, which must be flexible and easy to use.

But back to the bench. You need an easy way to find the problem, fast. You look at your latest set of collected data, and the timing lines from the keyboard interface wires suddenly say "bingo!" In normal operation, these lines should show no activity until you hit a key, but now they show transitions.

You see by looking at the code that the boot ROM loaded the BIOS properly from the disk, but then received garbage commands from the keyboard, sending the 8088 off into the wild blue yonder. You suspect noise on the keyboard interface lines. Upon further examination, you find that rough handling of the keyboard has caused some broken connections and that one of the lines is floating, generating the spurious inputs. So you fix it, and—voila!—it's time for coffee.

Choosing the best tool for the job

An oscilloscope is fine when you are dealing with repetitious signals, when the waveform itself is important and single-line, voltage-level triggering is adequate. But dealing with digital, non-repetitive signals requires a logic analyzer—when a symptom occurs just once, you have to be able to capture it. A logic analyzer permits complex, digital-word sequence triggering and provides long recording times.

Logic analyzers are becoming commonplace on the workbench. You need them everywhere now, because everything is digital and most equipment contains microprocessors. Analyzers are now less expensive and easier to use, yet they are offering more and more power.

The key features of a useful service-bench logic analyzer are:

- good triggering.
- non-volatile storage.
- high speeds on a few channels.
- wide widths for 16- and 32-bit microprocessors.



The logic analyzer is especially useful with digital, non-repetitive signals.

Blakemore is vice president of Arium Corporation.

This sample screen shows a time-stamped state/timing split-screen display.

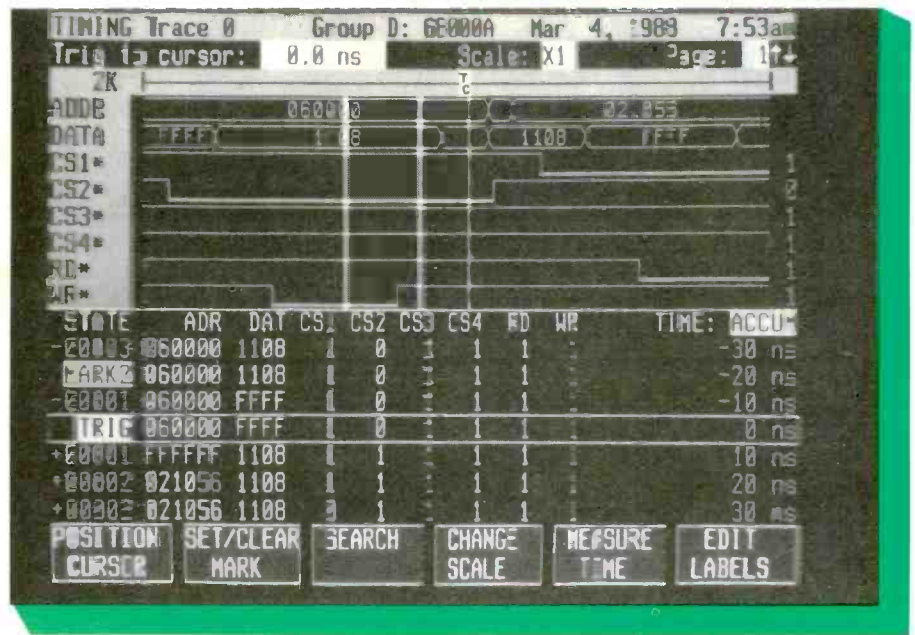

- light weight and small size (true portability).
- easy DIP-clip connections to target microprocessors.
- autocapture capability for continuous comparison when you are looking for intermittent failures.

An analyzer with good triggering will be able to set each trigger word to include external bits as well as status, address and data on microprocessors. It will have simple, standard sequences, such as "A then (B without C)", that are accessed by a single button. These pre-defined sequences will be augmented by user-defined sequences, which include multiple occurrences (such as "4 occur-

rences of A and B with D*") and Boolean combinations at the trigger words.

One final point: A good logic analyzer for the bench must also be priced

low enough that you can afford to put it on your bench. You need to balance the features you want with the price you can afford.



PACESETTER PRICE

50 MHz TEK 2210/2225

Best-of-class performance at

\$995/\$2195 Get the PaceSetter start in digital storage with Tek's NEW 50 MHz 2210. Featuring 20 MS/s per channel digitizing, 4K record length per channel plus familiar, full-bandwidth analog operation for just \$2195. And for pure and simple analog performance with unmatched economy, look at the popular, 2-channel Tek 2225—just \$995!

NEW 2210
20 MS/s per channel

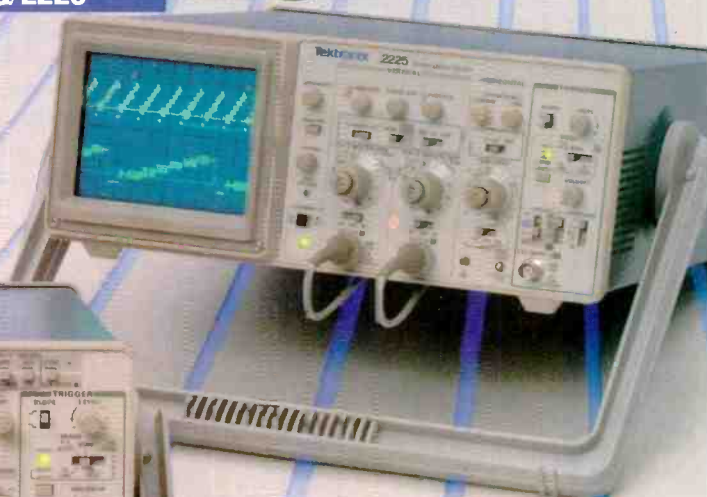
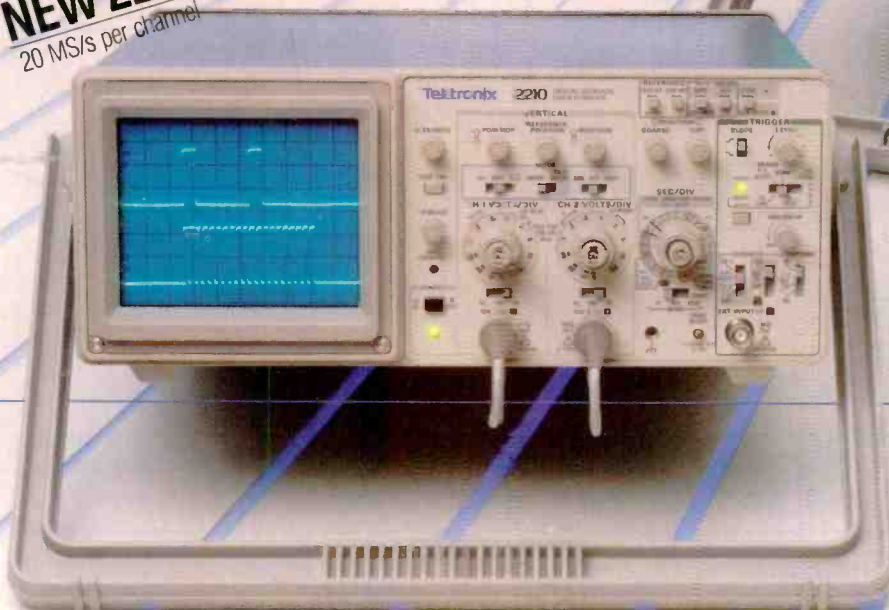

Call Tek direct
for PaceSetter specs!
1-800-426-2200

Prices subject to change without notice
Copyright © 1989, Tektronix, Inc. All rights reserved. TTA 906-C

Tektronix
COMMITTED TO EXCELLENCE
Circle (33) on Reply Card

Test your electronics knowledge

By Sam Wilson, CET

It is a good idea to review the basics every so often. Can you get 100% in this easy quiz?

1. Can you still name the six basic methods of generating a voltage?

2. A certain resistor has six color-code bands: orange, orange, orange, red, red, orange. When it is connected across an *exact* 5V supply, what is the maximum current that can flow if the resistor is in tolerance?

3. To remove a surface-mount transistor from a board, you must first remove the solder. Then, twist the transistor to break the epoxy holding it in place. To connect the transistor back to the board

B. put epoxy on the board only.
C. put a small amount of epoxy on both the transistor and the board.
D. None of the above.

4. Can you add a resistor to the circuit of Figure A so that the lamps are operated at their rated values?

5. If it takes exactly 25ms for an oscilloscope to produce one trace, what frequency delivered to the vertical input will result in a display of four complete cycles?

6. The maximum amount of induced voltage across an inductor occurs when the maximum rate of current occurs. If the sine-wave current in Figure B is flowing through the inductor, the maximum amount of induced voltage occurs when the instantaneous current is at

A. point x.
B. point y.

7. What is a material that has a permanent electric field?

8. Is the following statement correct? "The power dissipated by a resistor equals $V^2 \div R$, so if you double the voltage across a resistor, its power rating will be four times greater."

9. Is the following statement correct? "The voltage rating of a fuse tells what voltage must be across the fuse to make it blow."

10. Is the following statement correct? "The impedance of the circuit in Figure C is fixed, so doubling the applied voltage (V) will double the current and double the voltage drop across L_1 ."

Wilson is the electronics theory consultant for ES&T.

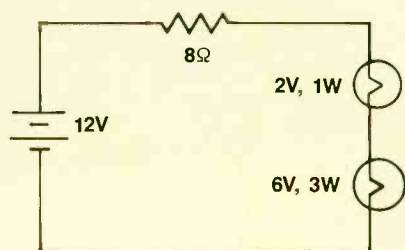

FIGURE A

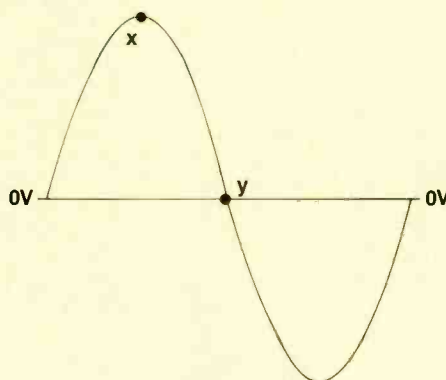

FIGURE B

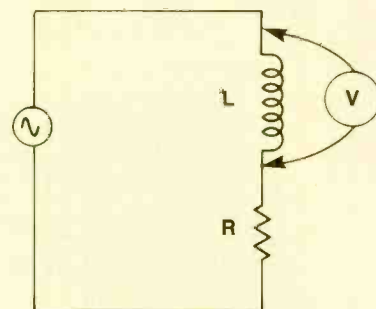

FIGURE C

Answers are on page 51.

Test accessory catalog

E-Z Hook has introduced a 116-page catalog of electronic test accessories. The catalog includes specifications, configuration diagrams and application examples for more than 12,000 product styles and sizes. Included are a miniaturized, E-Z Micro Double Grip-per test connector, test lead interfaces, BNC and DB coaxial test cables, and type N series connectors and cable assemblies.

Circle (125) on Reply Card

Electronic equipment catalog

Anasco has released a catalog of laboratory and service test equipment. The catalog provides technical specifications on more than 400 items, including multimeters, oscilloscopes, circuit analyzers, calibrators, power-control equipment, signal generators, counter/timers and more. The company also provides free telephone consulting to help customers choose the right equipment.

Circle (126) on Reply Card

Test instrument catalog

The *B&K-Precision Division* of *Maxtec International* has released the BK-88, a 68-page electronic test instrument catalog covering analog and digital storage oscilloscopes, IC testers, DMMs, signal and function generators, digital test instruments and more. The catalog provides complete performance and mechanical specifications in both detailed listings and summary comparison charts, and offers accessories for the instruments described.

Circle (127) on Reply Card

Computer/data comm catalog

Electro Standards Laboratory is offering a product catalog describing the company's line of computer accessories and data communication products. The catalog features RS-232 breakout boxes, cable adaptors, line drivers, modem eliminators, surge protectors, computer and printer switches, data cables, bulk data cable, PC cables and twin-axial interface products.

Circle (128) on Reply Card

Benchtop accessory catalog

The PM-57, 8-page catalog from *Desco Industries* describes the company's line of benchtop accessories for the elec-

tronic workbench. Another catalog, PM-56, shows the company's other line of products for controlling electrostatic discharge.

Circle (129) on Reply Card

Fiber-optic/digital instruments catalog

Intelco Corporation has published its

Telecommunication Test Instrument Handbook and Catalog for 1988. The catalog shows the company's line of fiber-optic test equipment, including optical power meters, attenuators, laser and LED source sets, and loss sets. TI, RS-232 and V.35 hand-held BER analyzers are also covered.

Circle (130) on Reply Card

ES&T



Immediate Delivery

DMM's at SALE PRICES!

3 1/2 DIGIT 3200 COUNT ANALOG/DIGITAL MULTIMETERS

Model 73
Value Leader-World's Most Popular DMM-Autoranging

\$69 reg. \$79

Model 75
Autoranging + Range Hold Audible Continuity Function

\$105 reg. \$119

Model 77
Touch-Hold Feature + Features of Model 75

\$129 reg. \$149

Model 37
Bench/Portable, 0.1 VDC Accuracy 10 A Range 2 yr. Warranty

\$219 reg. \$249

40th Year Anniversary Sale



3 YEAR WARRANTY

Model 77

Model 8021B

FREE SHIPPING!
FREE SHIPPING ON FLUKE TO UPS SHIPPABLE DESTINATION.

3 1/2 DIGIT HIGH-ACCURACY HAND HELD

Model 8021B
0.25% DC Accuracy, Audible Continuity Function

\$159 reg. \$179

Model 8020B
0.1% DC Accuracy, Audible Continuity & Conductance Function

\$189 reg. \$219

Model 8024B
0.1% DC Accuracy, 11 Functions Peak Hold, Temperature

\$225 reg. \$259

Model 8026B
0.1% DC Accuracy True RMS AC Volts & Current

\$199 reg. \$229

4 1/2 DIGIT TRUE RMS HAND HELD

Model 8360A
Measures True RMS AC Volts & Amps, dB + Frequency From 12 Hz to 200 KHz, Resistance to 300 M

\$325 reg. \$369

Model 8062A
Same as 8060A, but Less Frequency & dB

\$265 reg. \$299



Model 8060A
1 YEAR WARRANTY

TRUE RMS BENCH DMMs

Model 8010A
3 1/2 Digit 10 AMP Range

\$259 reg. \$299

Model 8010A-01
With Rechargeable Battery

\$299 reg. \$339

Model 8012A
3 1/2 Digit Two Low Ranges

\$319 reg. \$359

Model 8012A-01
With Rechargeable Battery

\$355 reg. \$399

Model 8050A
4 1/2 Digit Relative Ref. Function 0.03% DC Accuracy

\$355 reg. \$399

Model 8050A-01
With Rechargeable Battery

\$389 reg. \$439

*True RMS AC TO 50/ KHz

*Conductance Function Checks High Resistance

Send for FREE 480 page "Industrial Products Catalog". I understand it is FREE with any order or if requested on company letterhead. (Otherwise, \$4.95 to cover catalog and shipping costs.)

ORDER TOLL FREE
1-800-323-5925
IN ILLINOIS
312-297-4200
SINCE 1947

Joseph Electronics

IL Res. 7% Tax

JOSEPH ELECTRONICS, INC.
8830 N. Milwaukee Ave. Dept. F
Niles, IL 60648

Rush merchandise per attached order. I understand rated accounts are shipped open account; otherwise send per credit card.
 Visa Master Card Discover
 Check Money Order Rush Catalog

Card No. _____ Exp. Date _____

Name _____
Company _____
Street Address _____
City _____ State _____ Zip _____

Circle (16) on Reply Card

The digital storage oscilloscope:

Providing the competitive edge

By Brad Harris

Today's consumer electronics products are significantly more complex than they were even a few years ago, largely due to the ever-increasing power of electronics components and design. This complexity brings to the service technician both new challenges and a need for advanced tools to troubleshoot, calibrate and service electronic products. One such tool rapidly gaining popularity is the digital storage oscilloscope, or DSO.

Several factors have contributed to the growing acceptance of DSOs. First, prices have fallen significantly since the days when the DSO was confined to the domain of the research and development lab. As digital storage technology has

Harris is product marketing manager of the Portable Test Instruments Division of Tektronix.

matured, portable DSOs have become more cost effective. Second, the built-in features of a DSO are becoming better known in the service industry, largely because the benefits of simplified measurements and more efficient service procedures are giving companies a key competitive edge. Finally, the DSO has become more familiar and easier to use, making it a useful tool for the novice as well as the more experienced servicer.

DSOs offer many capabilities not available with traditional non-storage technology. These capabilities include capturing single-shot or transient events; enhancing the waveform display for troubleshooting or calibrating; displaying events that occur before a trigger

event; and applying advanced waveform processing techniques to servicing tasks. Combined with conventional analog features, these capabilities can boost your productivity while enhancing your accuracy and efficiency.

Capturing a transient

A fundamental benefit of digital storage is that it allows you to capture a transient or single-shot event. For example, you can easily capture a waveform, which might appear as a single blink on the trace of an analog oscilloscope, and either freeze it on-screen for detailed analysis or store it in digital memory for comparison to newly acquired data. Or you could examine a transient, such as a power-line surge caused by a motor

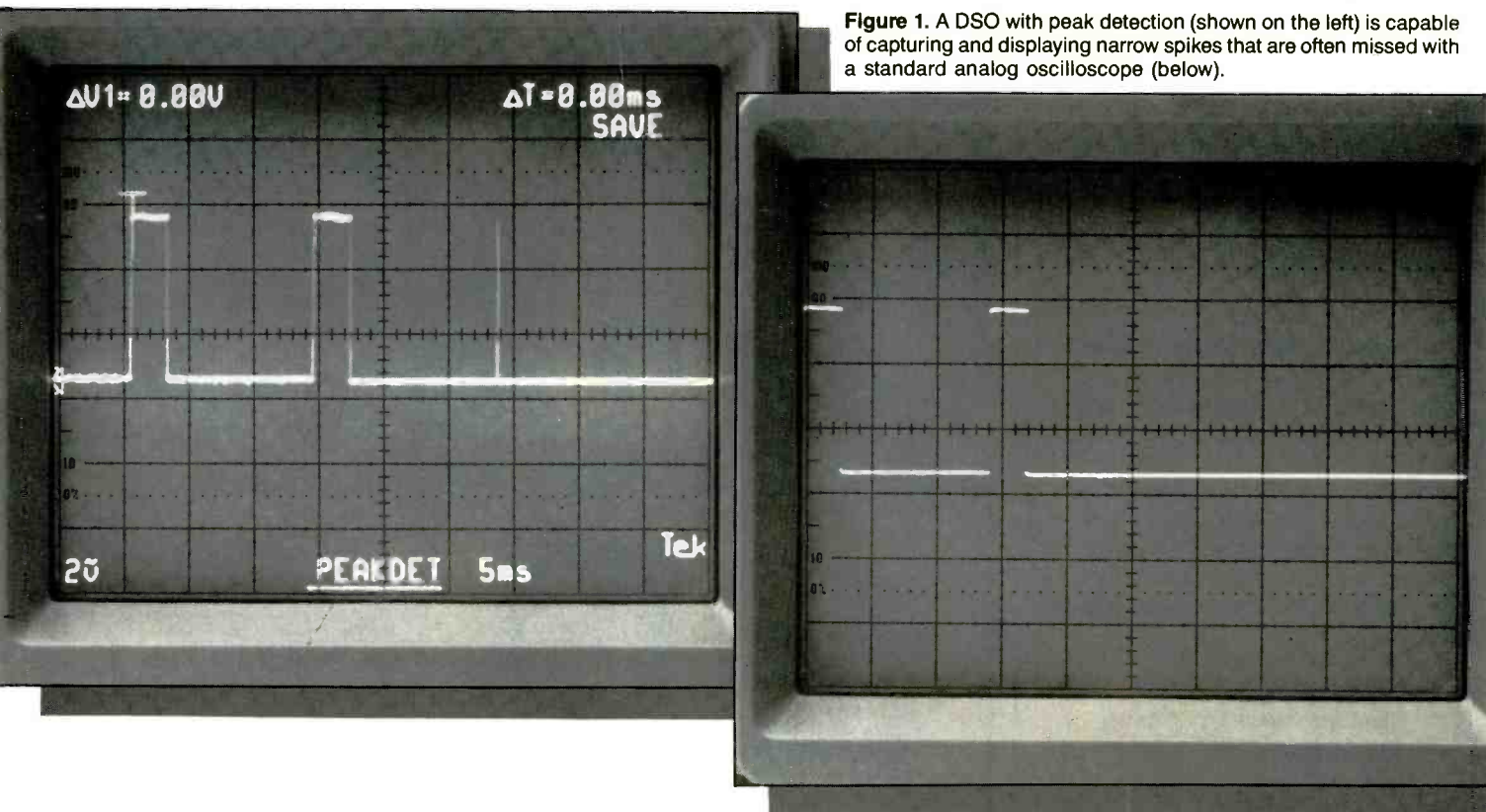

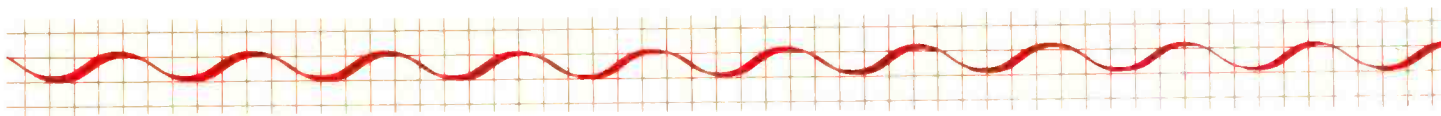

switching on or off, without continuously cycling the motor.

Searching for glitches caused by circuit crosstalk or electromechanical interference is also simplified. A narrow spike common with such glitches is all but invisible on a standard analog display, but a DSO is capable of displaying even narrow pulses with the same intensity as typical frequency events or pulse widths.

With a digital storage scope, it's also easy to monitor a problem circuit to catch an elusive glitch. For example, you can set up a DSO in babysitting mode and leave it unattended while it waits for a trigger event. When a glitch occurs, the DSO captures the event and stores it in memory.

Trace quality

Reducing eye fatigue is especially valuable in applications requiring low-repetition signals, such as the familiar *cats eye* pattern used for head radial alignment in disk-drive repair. A stable display of such signals also results in faster, more reliable measurements.

The display capabilities of a DSO are excellent for displaying low-repetition signals. A 60Hz line frequency, for example, can be difficult to view for extended periods of time on a conventional oscilloscope. Because of the signal's low repetition rate, the conventional oscilloscope's display tends to blink or flicker, quickly leading to operator fatigue as the trace is constantly redrawn across the CRT. The DSO, however, first digitizes the low-repetition signal, updates it from memory and displays a clear, stable, flicker-free waveform.

Reference memory

Adding one or more reference memories to a DSO further enhances the value of waveform storage. For example, you can store a previously acquired

waveform in one memory location and the current acquisition in another. What's more, both the reference waveform and the current waveform can be displayed simultaneously on-screen for rapid comparison.

This feature is especially useful during repetitive testing or calibration of a device to a standard waveform pattern. For instance, when evaluating the performance of a stepper motor, you can use your DSO's reference memory to acquire and retain a waveform from a functioning stepper motor. Then compare waveforms from subsequent motors being tested against the reference waveform. You can even reposition the reference waveform directly on top of the current acquisition to highlight differences.

You can extend the value of reference memories by providing non-volatile, battery-backed memory for retaining waveforms even after the DSO's power is switched off. Using a battery allows you to carry standard waveforms to different field sites or capture unfamiliar waveforms on-site and bring them back to the service center for further analysis.

Pre-trigger information

Another feature unique to digital storage technology is the capability to acquire and display pre-trigger data. An analog oscilloscope initiates a trace at the trigger point only; a typical DSO also can be set to display events leading up to a trigger point.

Pre-trigger viewing in a DSO is possible because the scope is constantly sampling the voltage value of an input signal. Thus, the trigger does not need to start the recording; it serves only as a reference point. Pre-trigger data is available because the scope reserves some portion of the waveform record for events occurring before this reference point.

This feature is especially valuable in power-supply testing. Just set the DSO to trigger at the power supply's stable output voltage, then arm it for a single sweep, with 75% of the waveform record being reserved for pre-trigger data. When you switch on the power supply, the DSO captures rise time data during power-up as part of the pre-trigger information, along with the subsequent ripple exhibited after the trigger point as the output voltage stabilizes.

Viewing pre-trigger data also provides an easy way to find the cause of a recurring circuit glitch. The glitch becomes the trigger event. The DSO captures information leading up to that point and displays it on-screen for analysis.

Signal processing

Signal processing capabilities provide a means for transforming raw waveform data into valuable information. In general, signal processing can be divided into two areas: enhancement of signal capture and subsequent data extraction.

One common method of enhancing signal capture, for example, is waveform averaging. By averaging together multiple waveform acquisitions, you can eliminate unwanted random noise riding on top of a repetitive signal, thus obtaining more precise and accurate measurements.

Record keeping

Finally, many DSOs offer the capability to document waveforms by interfacing with an external device via standard communication protocols. Options, which include GPIB or RS-232 interfacing, allow waveforms to be transferred to another device such as a printer or a personal computer.

With this capability, you can document waveforms in hard copy or retain them in standard PC memory media such as a floppy disk. You might even

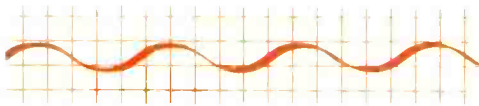

create a library of standard waveforms used in servicing various equipment. The appropriate waveform can be downloaded to the DSO's reference memory when needed. You also can maintain a complete service record for a particular unit being serviced without using analog plotters or CRT cameras. In addition, preprogrammed test routines can be saved in a controller's memory, then recalled as part of a standard test procedure and sent to the DSO for execution.

The DSO's interfacing capabilities make teleservicing possible. With a telephone modem, a service technician in the field can gain access to a central waveform database. The technician could also transmit the waveforms encountered to the main servicing facility, enlisting the diagnostic assistance of other technicians.

Digital storage technology

The principal difference between a DSO and its analog counterpart is the addition of a *digitizer*, or analog-to-digital (A/D) converter. The digitizer transforms an analog signal into discrete voltage values over time, then stores

these values in memory as a digital record of the waveform. This process consists of two steps: *sampling* and *quantizing*. A waveform is sampled to obtain a voltage value of the input signal at sample points equally spaced in time. Quantizing then transforms the voltage value into a binary number for storage.

The resolution for transforming continuous values into discrete values is determined by the number of *bits* (from binary digit) available to the A/D converter. A 2-bit converter, for example, would have four (2^2) discrete amplitude levels available to describe a signal at any given time. (For example, for a full scale of 0V to 10V, levels would range from 0 to 2.5, 2.5 to 5.0, etc.) The higher the number of bits available to the digitizer, the greater the subdivisions of a full vertical scale. For example, an 8-bit digitizer has 256 levels, while a 10-bit digitizer has 1,024 levels (or 1/100th of a division).

Although a higher number of bits allows greater discrimination between voltage values, the accuracy of your DSO measurement may be limited by other factors, including the accuracy of the vertical amplifier. Thus, the accuracy of a DSO is normally specified consistent with its analog counterpart (typically 2% to 4%). The usefulness of a high number of bits available to the

digitizer also may be limited by screen resolution or cursor measurement accuracy. For instance, the resolution of a CRT screen is limited by its spot size, which typically ranges from 1/25 to 1/50 of a division.

Horizontal resolution

Waveform record length also has an impact on signal detail. Generally, the more samples recorded during a given unit of time, the greater the horizontal resolution. Longer record length provides the advantage of capturing an entire waveform event while maintaining the time resolution needed for detailed analysis.

For example, a transient waveform often displays a fast rise time, requiring a fast time-base setting for reasonable sampling resolution (lots of samples per unit of time). Yet, without adequate record length, such a fast sweep setting may result in a record duration that is too short to capture the entire transient. Conversely, slowing the sweep speed in order to display the whole signal may result in inadequate resolution for the fast-rising edge. The solution is a longer record length.

Some DSOs offer the flexibility of varying the record length for each application. This capability, however, involves a tradeoff—resolution vs. record update rate. The tradeoff exists because as more samples are taken, the time required to fill the record and display it on-screen becomes longer.

Sampling rate

The *sample rate*, or frequency at which a sample is taken, is the final factor in determining the level of detail of a digitized waveform. The sampling rate (also known as the *digitizing rate*) is usually expressed in terms of the maximum number of samples that can be taken in one second by the A/D converter (for example, 10 megasamples per second, or 10MS/s).

Another way to express sampling rate is by the *sampling interval*, or period of time between sample points. Sample interval is the inverse of frequency. (For example, at 10MS/s, the digitizer is sampling every 100ns.)

In order to relate sampling rate to a bandwidth specification, you need to understand the method of sampling being used. There are two different sampling techniques: *real-time sampling* and *equivalent-time sampling*.

In real-time sampling, all samples are

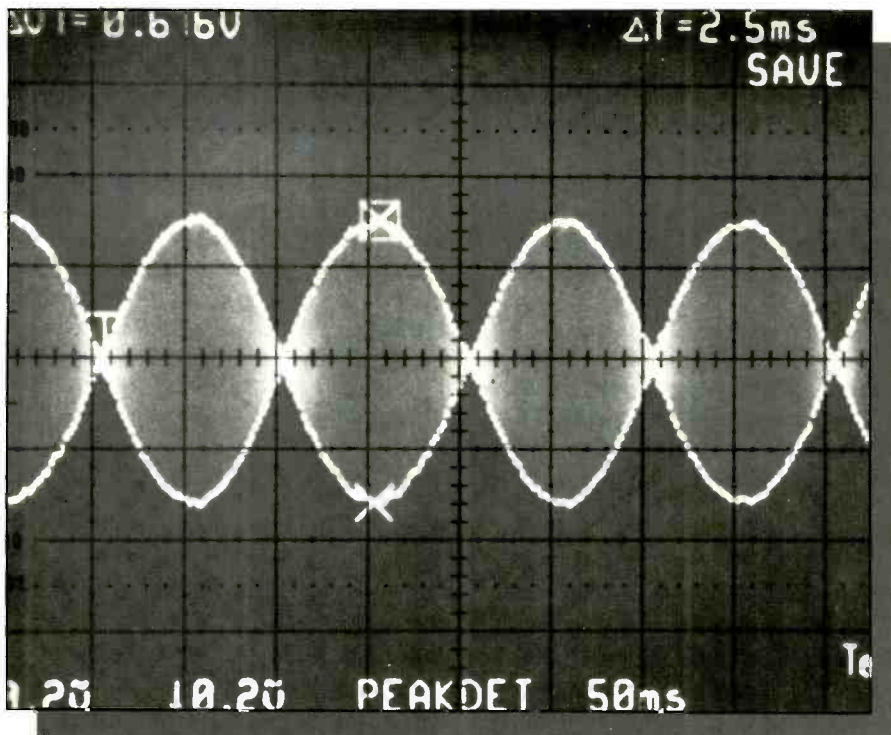
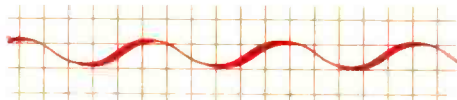

Figure 2. The DSO provides a stable, flicker-free display for displaying low-repetition signals. In this example, a head radial-alignment waveform (cat's eye) is displayed for on-screen amplitude measurements.



taken sequentially over a single acquisition of the waveform, as in capturing a single-shot event. Because there is only one sweep of the waveform, all samples must be taken in real time. This limits the useful storage bandwidth for single acquisitions to two factors: the number of samples that can be taken during a single sweep and the number of samples required to characterize a given waveform.

Theoretically, a sine wave can be characterized by only two points (according to Nyquist theory). Thus, real-time sampling is capable of capturing a single-shot waveform with frequency components as fast as half the sample rate.

In reality, however, you need more data points per cycle to adequately define or measure the transition parameters of a more complex waveform. Therefore,

the useful storage bandwidth is typically considered at a rate that can capture six to 10 samples or more per waveform cycle. For example, a DSO with a 20MS/s sampling rate would have a useful bandwidth of 2MHz if 10 data points per cycle were expected to characterize the waveform.

Another sampling technique, equivalent-time sampling, extends the useful storage bandwidth of a DSO. With repetitive waveforms only, a full complement of sample points can be built up over several sweeps of the waveform. During each sweep, a small portion of the waveform detail is captured. This process repeats until a full record is available to reconstruct the complete waveform. Equivalent-time sampling can generally extend a DSO's useful frequency range to match the analog input bandwidth of the oscilloscope.

Actual sampling rate vs. time setting

Although a DSO is specified by its

maximum sampling rate, the actual rate used in acquiring a given waveform is usually dependent on the time-per-division setting of the oscilloscope. The record length defines a finite number of sample points available for a given acquisition. The DSO must, therefore, adjust its sampling rate to fill a given record over the period of time set by the sweep speed.

To determine the sampling rate for a given sweep speed, you simply divide the number of *displayed points per division* into the *sweep rate per division*. For example, a DSO with a 1K display record length has 100 sample points per division. Dividing this value by the sweep rate per division gives you the sampling frequency (subject to the maximum rate of the digitizer clock). With a 1s/division sweep rate, the sampling rate would be 100 samples per second (or a 10ms sampling period). At 5 μ s/division, the sampling rate increases to 20MS/s (100 points/division divided by 5 μ s/division), or 50ns between sample points. By adding more points to the displayed record length, the actual sampling rate increases. (For example, with 400 points per division, a 1s/division sweep setting would result in 400 samples per second, or 2.5ms per sample point).

Two additional features can modify the actual sample rate. The first is the use of an external clock for pacing the digitizing rate. With the internal digitizing clock disabled, the digitizer will be paced at a rate you define. The source of the external clocking signal could be linked to a trigger event, causing the DSO to take a sample at each turn of a motor, for example.

The second method of modifying the actual sample rate is known as *peak detection* or *glitch capture mode*.

Peak detection

Peak detection allows the digitizer to sample at the DSO's full digitizing rate, regardless of the time-base setting. The minimum and maximum values found between each normal sample interval (as defined by the time-base setting) are retained in memory. You can use these minimum and maximum values to reconstruct the waveform display using a special algorithm that recreates a smooth display along with any captured glitches.

Peak detection allows the DSO to capture glitches even at its slowest sweep speed. Regardless of the time-base set-

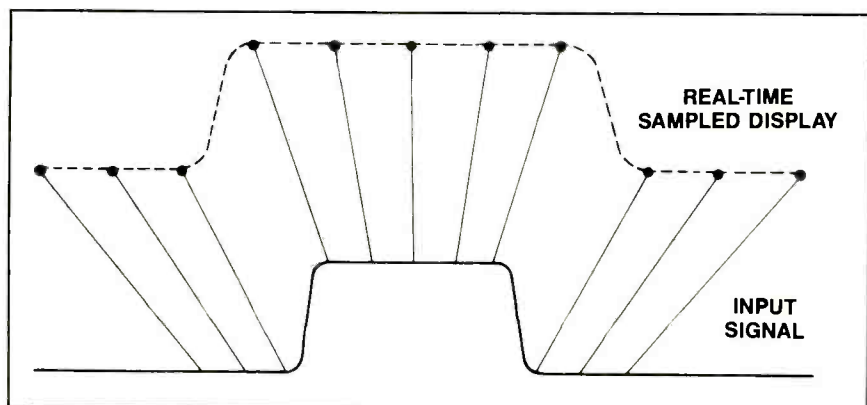

Figure 3. In real-time sampling, each point is displayed as it really occurs in time. Only one complete sweep is needed to display the input waveform.

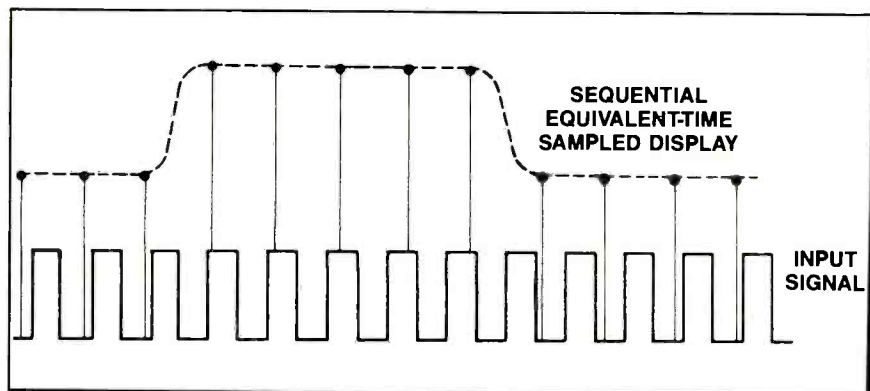

Figure 4. In equivalent-time sampling, successive samples of the signal to be captured are taken over many stable waveform repetitions. The signal is reconstructed from the samples.

ting, peak detection enables the DSO to place samples on narrow pulses discovered by sampling at its fastest rate. For example, a digitizer capable of sampling at 10MS/s can detect excursions as narrow as 100ns, even when viewing a 50s event. Without peak detection, such glitches can easily fall between samples and be missed entirely.

One method of peak detection provides for even greater troubleshooting efficiency. Known as *peak-accumulation* or *envelope mode*, this approach accumulates and displays the maximum and minimum excursions of a waveform for a given point in time. This approach builds an envelope of activity that can reveal infrequent noise spikes, long-term amplitude or time drift, and pulse jitter extremes. Figure 5 illustrates the advantage of peak accumulation when variations in data pulse width are monitored.

Once you've reviewed the basic DSO specifications, the next task is to decide which features are most beneficial to your application. Will you require capturing and displaying glitches that occur between normal sample intervals? How many reference memory locations will you need? Do you need point-selectable pre-trigger data? How much post-acquisition waveform processing do you need?

Choosing a DSO

When selecting a DSO, you should determine what type of signals you normally measure—are they repetitive or transient, and how frequently do they occur? As described earlier, these factors affect the storage bandwidth and sampling methods required.

You should also consider what level of signal detail you need. Are you seeking accurate waveform parametric data, or are you merely comparing against a visual standard (for example, when calibrating)? Remember, signal detail is determined by the number of digitizer bits, the record length and the sample rate.

Once you've reviewed the basic DSO specifications, the next task is to decide which features are most beneficial to your application. Will you require capturing and displaying glitches that occur between normal sample intervals? In this case, peak detection will be a valuable feature. How many reference memory locations will you need, and should they be battery-backed? Do you need point-selectable pre-trigger data? How much post-acquisition waveform

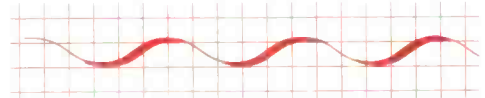

processing do you require? Would you benefit from interfacing over a built-in communications port to a plotter, a printer or an external controller such as a PC?

Features common to conventional oscilloscopes also should be included in your purchase criteria. Will you need,

CALL TOLL FREE
Include work address and
phone number for Free Catalog.

800-824-2873

DIGITAL MULTIMETERS

BECKMAN

Beckman Industrial!

- All 300, HD, and Circuitmate series
- All accessories in stock

MODEL	PRICE
HD100	\$169
HD110	\$199
HD130	\$259
HD140	\$279
300	\$120
310	\$145
310B	\$155
320	\$179
320B	\$189
330	\$219
350	\$229
360	\$289
4410	\$239

FLUKE

- Autorange Analog display
- Touchhold function
- 0.3% accuracy Heavy duty

MODEL	PRICE	MODEL	PRICE
21	\$ 99	75	\$119
23	\$149	77	\$149
25	\$199	8010A	\$299
27	\$259	8012A	\$359
37	\$249	8020B	\$219
52	\$169	8024B	\$259
73	\$ 79	8050A	\$399

Hand held DMM

FLUKE 23YEL

SALE \$120

LIST \$145

WAYNE KERR

MODEL	PRICE
4210	\$2650
4225	\$1950

SCOPES

HITACHI

Hitachi

Denshi America, Ltd.

- All 20 models in stock
- 2-3 year warranties
- 20-100 MHz

MODEL	PRICE
V209	\$ 895
V222	\$ 530
V422	\$ 740
V425	\$ 796
V660	\$ 985
V665	\$1255
V680	\$1341
V1060	\$1345
V1065	\$1615
V1100A	\$2116

HITACHI V-509

Portable Dual Trace Scope

SALE \$1199

LIST \$1445

IWATSU



- All 14 models in stock
- 2-3 year warranties
- 20-250 MHz

MODEL	PRICE
5702	\$ 535
5705	\$ 899
5706	\$ 749
5710	\$1245
5711	\$1695
5712	\$2999

POWER SOURCES

POWER DESIGNS

- Low and high voltage power sources
- 1-5 year warranties

MODEL	PRICE
TP340	\$ 805
TP343A	\$ 855
TW347D	\$ 855
TW5005D	\$ 625
TW6050D	\$1075
2K20A	\$1095
2020B	\$ 850
4050D	\$ 805
5020	\$ 925
6010D	\$ 495
6150	\$ 775

USED TEST EQUIPMENT, TOO!—OVER 3,000 MODELS AVAILABLE AT HUGE DISCOUNTS WITH WARRANTIES!

■ Quantity Discounts Available ■ Dealers Welcome ■ Freight and Tax Extra ■ Immediate Availability of Equipment

United States Instrument Rentals, Inc.

A U.S. Leasing Company
2988 Campus Drive
San Mateo, CA 94403

Circle (14) on Reply Card

June 1988 *Electronic Servicing & Technology* 25

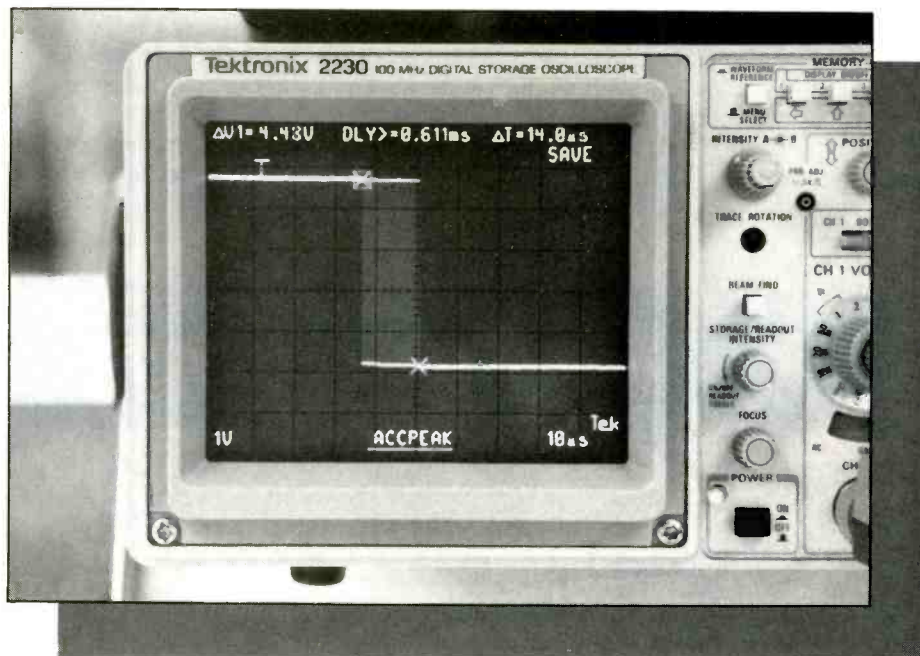

Figure 5. Accumulate peak-detect mode reveals signal excursions over time—in this case, variations of data pulse width.

for example, analog capabilities along with digital advantages to display complex waveforms in real time? Are measurement cursors or advanced signal-processing features valuable for your application? How portable is the unit? Is it rugged enough to withstand the rigors of service applications? Is the unit third-party certified for safe and reliable operation? What are the anticipated after-purchase costs (length of warranty, reliability and after-sale support)? Finally, how simple is the oscilloscope to learn and operate?

By carefully considering all of these factors, you can significantly simplify the task of selecting a DSO for your application. Understanding how you use an oscilloscope today and how you anticipate using it in the future is the first step. Considering the advantages of digital storage technology—enhanced productivity and improved accuracy—is the next step.

ES&T

Books/Photofact

Editor's Note: Please direct inquiries to the addresses given beneath each book write-up rather than to ES&T.

Understanding Data Communications, 2nd Edition, by Gilbert Held; Howard W. Sams & Company; 304 pages; \$17.95.

This book combines a general overview of data communications with detailed explanations of specific technologies. It includes all features of the Understanding series plus review questions and answers at the end of each chapter. Asynchronous and synchronous modems, network design and management and digital multiplexing are emphasized. V.22bis and Packetized Ensemble Protocol modems are also covered.

Howard W. Sams, 4300 W. 62nd St., Indianapolis, IN 46268; 800-428-SAMS.

Crash Course in Electronics Technology, by Louis E. Frenzel, Jr.; Howard W. Sams & Company; 400 pages; \$21.95.

The third book in the Crash Course series, this book is a tutorial to help hobbyists, technicians, students and laypersons learn basics of electricity and electronics. In a step-by-step, self-paced, self-instructional format, electricity is introduced and followed by a discussion of circuit basics and electronic devices. The book then presents a discussion of electronic communication, controls, motors, test equipment and troubleshooting with illustrations and examples.

Howard W. Sams, 4300 W. 62nd St., Indianapolis, IN 46268; 800-428-SAMS.

PHOTOFACT

EMERSON

2579-1 MS-25IDA
2585-1 ECR216A, ECR216A
(SUFFIX A)

MAGNAVOX

2582-1 CHASSIS 19B101/2/3/4/
5/6/7/8/9, 20B101/2/3/4/5/6

PANASONIC

2584-1 . . . CTJ-2042R-1, CTJ-2053R-1

QUASAR

2581-1 TL9940BK/48BP/51BK,
TYL9940BP/51BK

SEARS

2580-1 . . . 564.48124750, 564.48124751

TEKNIKA

2581-2 TF2687
2583-1 FH202, TF2085
(CH. ECC-2111)

TOSHIBA

2580-2 CF307, CF307C
2582-2 CF2037,
CX2007C/37/50C/57/57C
2584-2 CF2047, CX2047C
2585-2 CX2077, CX2077C

ZENITH

2579-2 C2020H,
SC2023H/27S/97W
2583-2 CI308S, C3338W,
V3308W

ES&T



PHILIPS

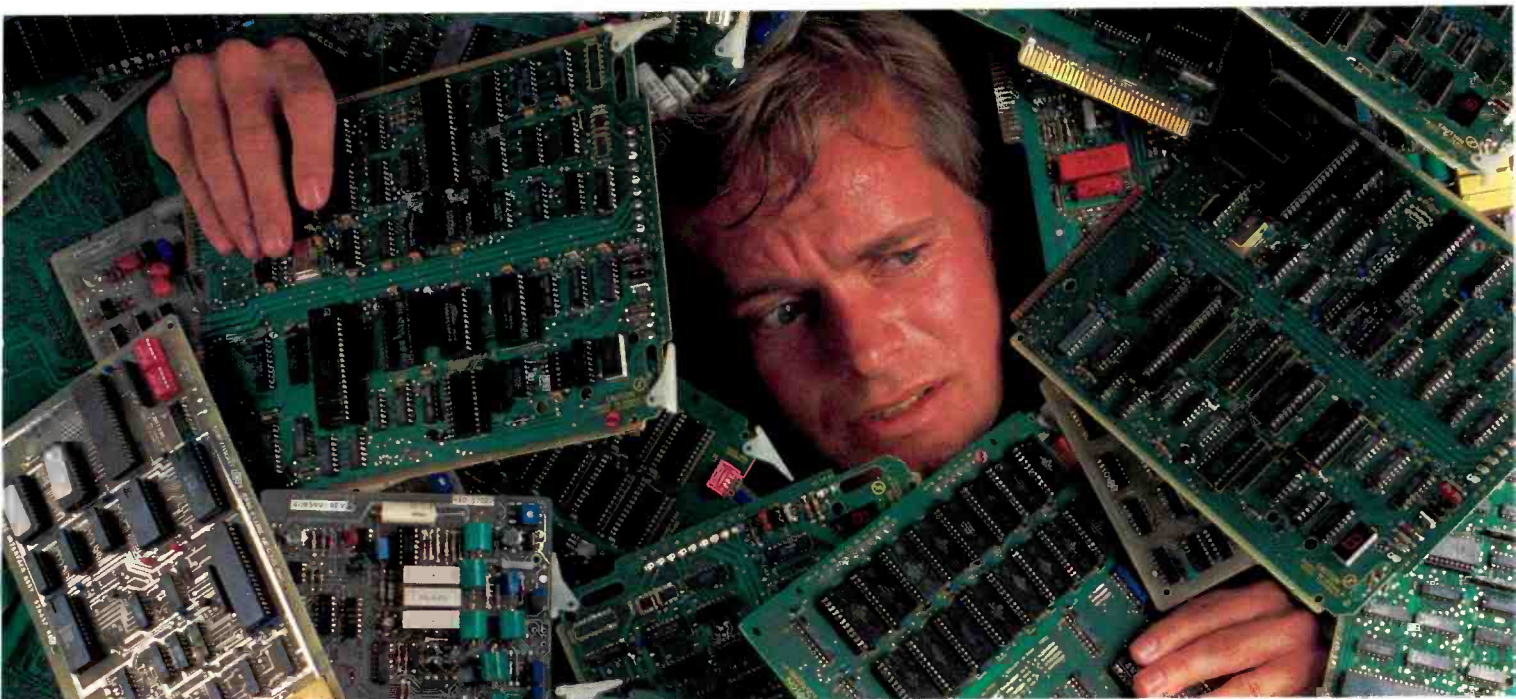

How to rescue yourself from a landslide of microprocessor board failures.

Complementing traditional troubleshooting tools, the Fluke 9010A can help decrease your board repair times by 55-80%.

You've got your oscilloscopes, your logic analyzers and your signature analyzers. But Fluke offers a better way to troubleshoot: the tool you'll reach for most. It's the 9010A Troubleshooter, a versatile board tester that's so easy to use, you can start testing the very first day.

The Fluke 9010A has a proven track record in saving repair time and substantially reducing board float. In fact, it has become the microprocessor repair tool of choice for over 2800 companies worldwide, including the leading computer and electronics manufacturers.

Test the easy way: from the microprocessor socket.

To begin board repair, remove the microprocessor from its socket and insert the interface pod connector in its place. Each

element of the microprocessor kernel (the bus, ROM, RAM and I/O) can be tested with a few simple commands.

Fluke's patented emulation technology offers real time testing and complete visibility throughout the circuit. This lets you test even the tough problem areas, including DMA, disk, video, communications and peripheral controllers. All diagnostic messages are presented in simple-to-understand English.

Comprehensive support from Fluke.

The 9010A supports over 50 microprocessors (including 180X, 6502, 680X, 680XX, 803X, 804X, 805X, 808X, 874X, 80X86, 9900, Z80, Z800X, 8751). And it is backed by Fluke's complete support network, which offers training courses nationwide on test strategy, basic operation and even μ P fundamentals.

In addition to the 9010A, the leader in emulative board test technology also offers the 9100A Digital Test System for a fully automated repair solution; plus the 90 Series, a compact inexpensive troubleshooting solution for 6809, Z80 and 8085 μ Ps.

To learn how you can escape the landslide, get your free video brochure "The 9010A μ P Board Repair Solution."

Call 1-800-44-FLUKE, EXT. 88 today.

John Fluke Mfg. Co., Inc. P.O. Box C9090,
M/S 250C, Everett, WA 98206.
U.S.: 206-356-5400 CANADA: 416-890-7600.
OTHER COUNTRIES: 206-356-5500.

© Copyright 1988 John Fluke Mfg. Co., Inc.
All rights reserved. Ad No 0181-F9010.



The 9010A Microsystems Troubleshooter

See us at
ATE East, Booth #634



Circle (15) on Reply Card

Audiotape gets rapid transit

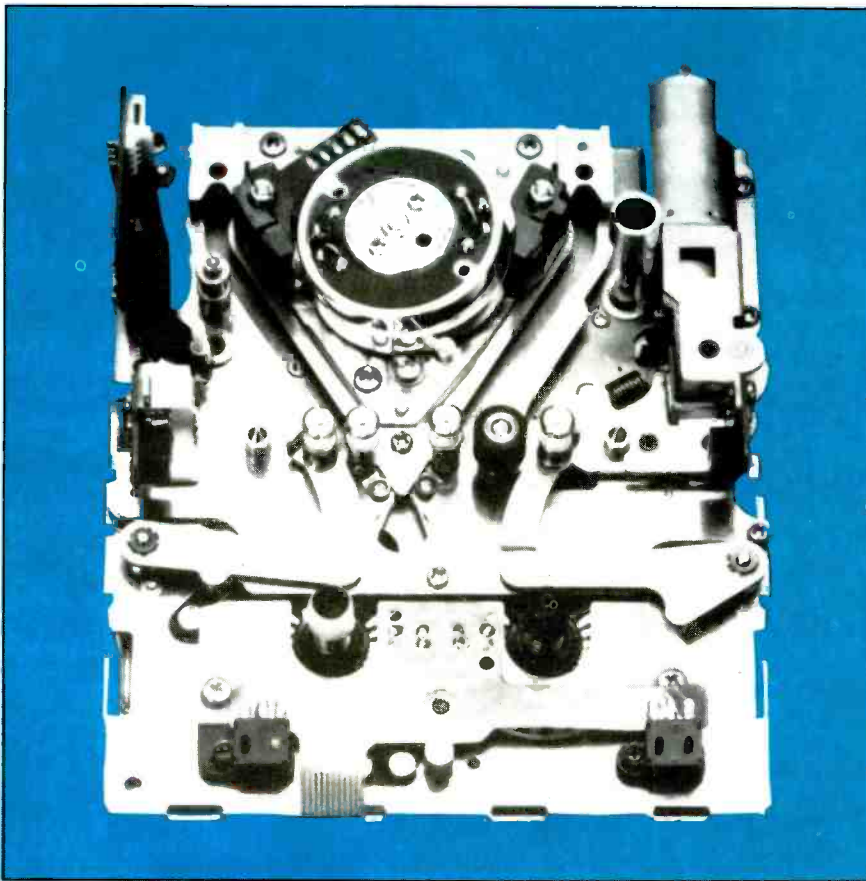

The F.A.S.T. R-DAT tape-transport mechanism uses a symmetrical link-arm mechanism that rides in precision V grooves. The link-arm loader allows playback within 2 seconds of receiving the command. A half-load position allows tape search at speeds almost 400 times greater than real time (twice the speed of conventional transports).

Nakamichi Corporation has announced an R-DAT tape-transport mechanism that provides more precise tape guidance and higher search speeds.

The mechanism, called F.A.S.T. (for fast-access stationary tape guide-transport), can perform a tape search at almost 400 times real time, or twice the speed provided by conventional transports. A half-load position allows the faster search speed with less tape damage than a conventional mechanism with full-load search.

The mechanism also differs from conventional transports by using a symmetrical link-arm mechanism that rides in precision V grooves. The link-arm loader also provides faster startup. Playback begins less than 2 seconds after the command is given.

A primary difference between the F.A.S.T. mechanism and conventional R-DAT designs is the use of stationary tape guides at both sides of the head drum. In other transports, the position of the tape against the head drum is determined by inclined pins that ride on the tape-loading arms. Because the pins move the arms, the precise position of the tape cannot be ensured from one loading operation to the next. In the F.A.S.T. mechanism, precision slot guides are mounted to the chassis in a fixed relationship to the head drum, ensuring a stable tape path.

The mechanism is compatible with DAT Conference Standards and can be used in DIN-sized mobile DAT players as well as in home decks. Nakamichi will use the mechanism in an upcoming line of DAT decks. The company also has entered into an arrangement with a leading Japanese supplier to provide the transport to other tape-deck manufacturers.

ES&T
inc.



PHILIPS

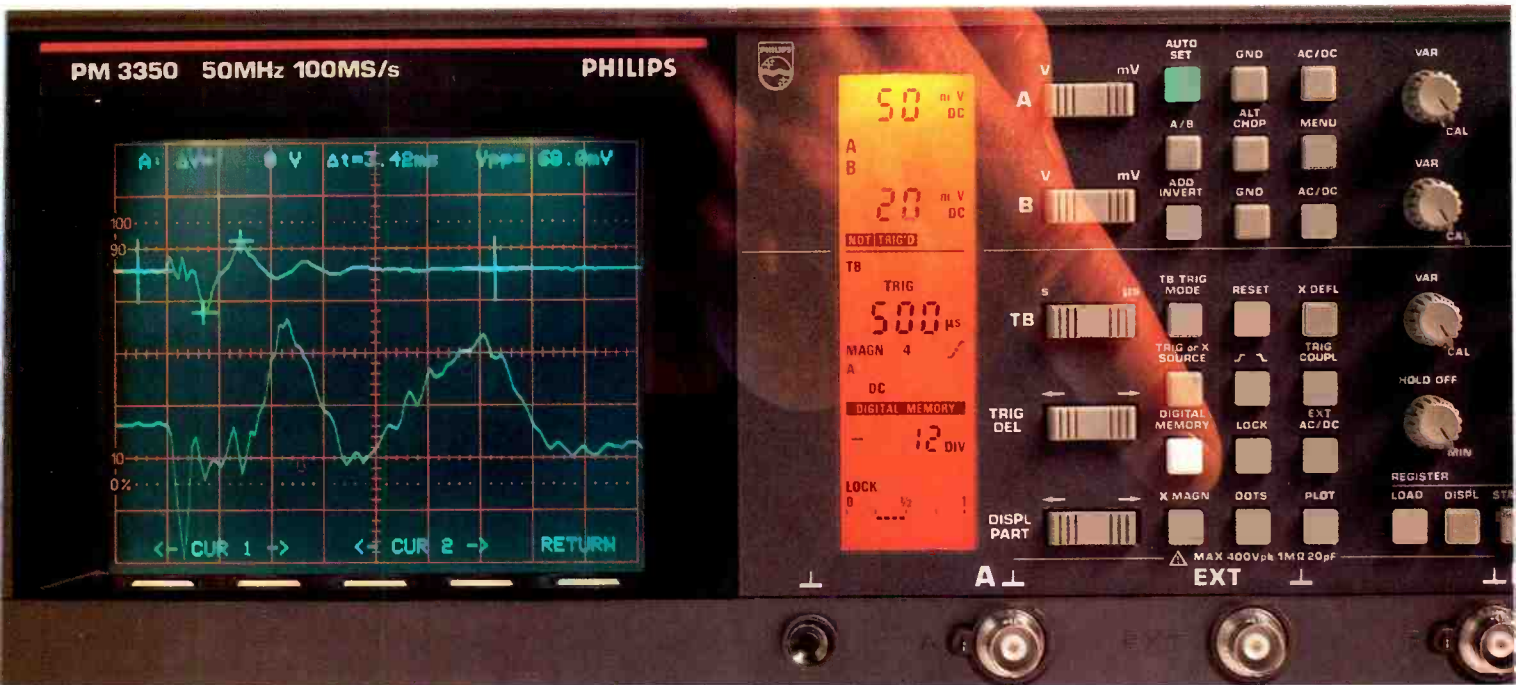

Breakthrough! The first fast digital with analog for <\$4,000

It's here. The Philips PM 3350 Digital Storage Oscilloscope. High-speed digitizing plus full analog capabilities for half what the next-best DSO would cost you. Unbelievable!

BREAKTHROUGH PERFORMANCE

- 100 MS/s sampling speed on both channels simultaneously allows you to capture fast phenomena having low repetition rates—even single shots—with excellent resolution. A first in this price range!
- True 8-bit vertical resolution offers precise signal display and measurement.
- Deep reference memory lets you store and compare waveforms with ease.
- Plus, you get full, dual-trace 50 MHz real-time familiarity at the touch of a button.

FAST, CONFIDENT OPERATION

- **AUTOSET** automatically selects amplitude, timebase and triggering for error-free, instant display of any input signal on any channel—in both digital and analog modes!
- **LCD panel** serves as the text information center, offering clear, at-a-glance alphanumeric read-out of all instrument settings; saves screen area for uncluttered waveform viewing.
- **Cursors** supply instant voltage, timing, frequency, amplitude and risetime measurements.
- **Softkeys** grant you simple, direct access to over 40 different functions via on-screen menus.
- **IEEE-488 or RS 232 interface options**

for fast computer/controller hook-up, data transfer and printing hard copies.

COMPLETE SUPPORT

The Philips PM 3350 comes with a 3-year warranty and all the technical and service assistance you need. From Fluke—the people who believe that extraordinary technology deserves extraordinary support.

TEST THE DIFFERENCE

Call Fluke today at **800-44-FLUKE ext. 77**. And make a break with the past.

John Fluke Mfg. Co., Inc., P.O. Box C9090, M/S 250C, Everett, WA, 98206
U.S.: 206-356-5400 CANADA: 416-890-7600
OTHER COUNTRIES: 206-356-5500

© Copyright 1988 John Fluke Mfg. Co., Inc.
All rights reserved. Ad No. 0181-P3350



PM 3350 • 50 MHz • DIGITAL STORAGE SCOPE

Circle (10) on Reply Card



Repair that digital DMM

By Victor Meeldijk

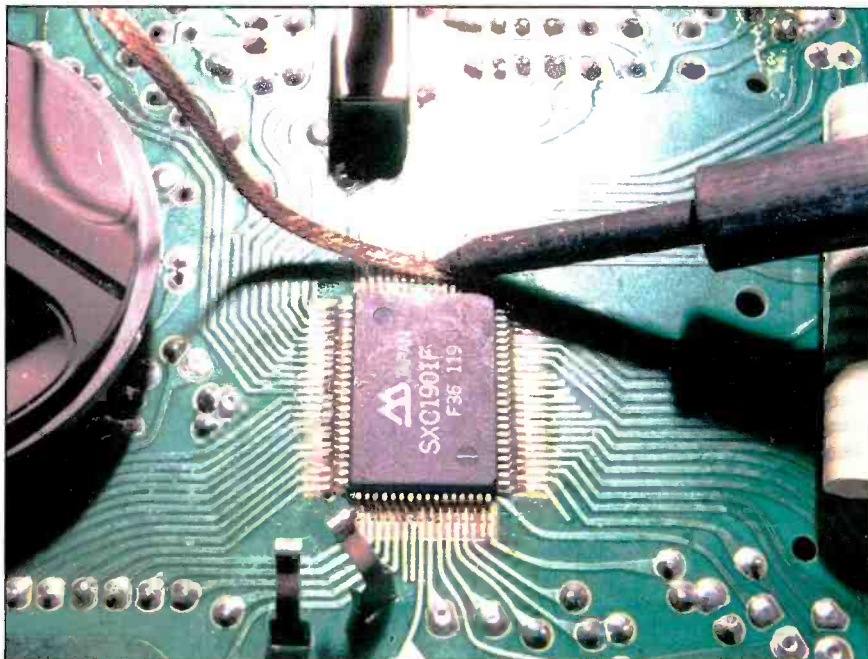
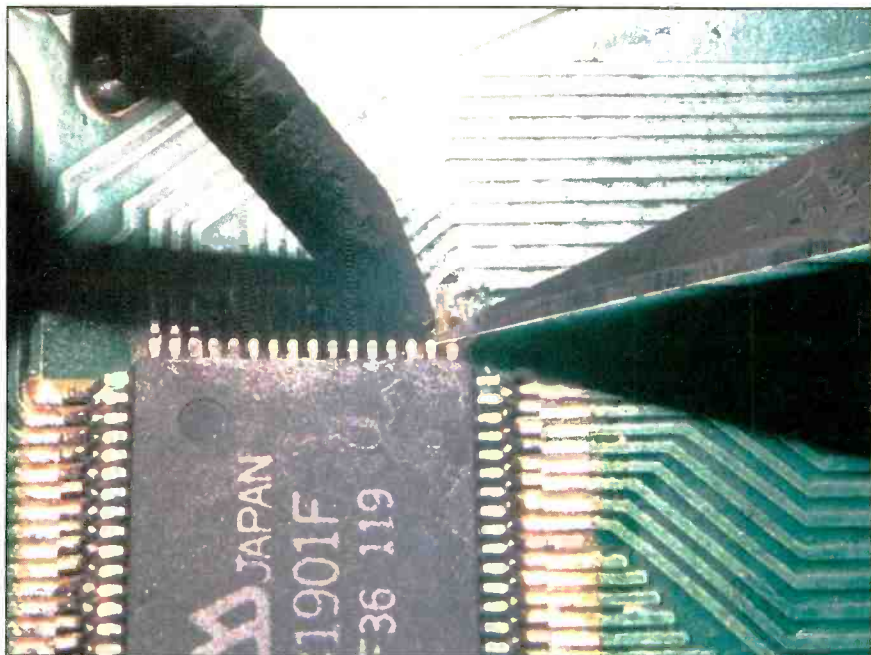

Figure 1. Desoldering braid is used to replace the 80-pin, surface-mount IC. A grounded soldering iron and a wrist strap prevent ESD to the static-sensitive IC.

Figure 2. After desoldering, each connection is heated and gently lifted from the circuit card with a sharp, pointed knife.



Before you throw away that multimeter, try to repair it. This actual case history of the diagnosis and repair of a Radio Shack Microna LCD digital multimeter (model 22-192) also illustrates practices that should be followed with any repair.

The DMM came back from the calibration house with this notation: "Meter will not zero in the ohms-adjust range, reads 30.7 Ω , defective IC, not economic to repair." Having had a previous experience where the repair was actually easier and cheaper than was estimated, I decided to attempt an evaluation/repair.

The first step, confirming the failure symptoms, showed that with the leads shorted, the meter reading was in the range of 150 Ω .

I opened the unit, taking care to observe static sensitivity handling procedures (with a table mat and a wrist strap), and examined the circuit. No parts appeared to be missing, but a few solder connections had been resoldered (with flux residue left on the board), and a ground trace to some circuitry had been cut. After cleaning the flux and repairing the cut trace, I took some measurements on the defective DMM and on an identical unit that functioned properly. (See Table 1 for the values read during those tests.)

The results of those measurements seemed to indicate that the problem was isolated to the resistance section of the DMM, although the calibration of the voltage section needed adjustment. The next step was to check the precision resistors used in the resistance measurement section. Using the values indicated on the schematic (Figure 1) and the resistor color bands, I obtained the results shown in Table 2.

Next, the OVX-OVS sections and the surge absorber were checked. The results are tabulated in Table 3.

Meeldijk is reliability/maintainability engineering manager at Diagnostic/Retrieval Systems.

PANAVISE PRODUCTS FOR TODAY'S TECHNOLOGIES

For over 30 years, PanaVise has made work holding devices for a variety of industries. Our newest line is created specifically for the electronics professional! PanaVise experience and made-in-USA quality ensure years of reliable, long-lasting service.



STANDARD PANAVISE: The original "tilt it, turn it, hold it anywhere you want it" vise with the patented split ball. A single control knob lets you position work in three planes—without removing it from the unit! Opens to 2 1/4" and comes standard with tough, yet gentle nylon jaws for improved grip. Steel, brass, Teflon® and grooved nylon accessory jaws sold separately. Model #301. Suggested retail \$33.95.

The readings for TR₁ were not identical for the defective and control-unit DMMs, which could still indicate a defective IC. I needed to conduct more tests to be sure.

As is the case when most multimeters are tested, resistance measurements are actually made by measuring the voltage drop across the device under test. In the case of this DMM, resistance is measured by applying a known constant current to the unknown resistance and measuring the resultant voltage drop. The voltage divider components were, therefore, the next logical components to check. For the results of these tests, see Table 4.

Using the range-hold switch, I checked the current/voltages available at each resistance range. (These values are listed in the owner's manual.) See Table 5 for the results of these tests.

Replacing the IC

These results were again inconclusive and did not pinpoint any discrete component as being defective. At this point, I determined, by a process of elimination, that the IC was defective. I ordered a new part (number MX-5227) from Tandy National Parts. A service manual (part number MS-2200192) was also available.

To replace the 80-pin, surface-mount IC, I used desoldering braid on all the solder connections (see Figure 1), applying heat with a grounded-tip soldering iron to prevent possible electrostatic discharge damage. Each connection was then heated and lifted with a sharp, pointed hobby knife (Figure 2).

After removing the IC, I aligned the new part with the PC card traces and held it down with a finger. I then made solder connections to each corner of the device in order to hold the IC's alignment while all the other solder connections were made.

After the IC was replaced, I again tested the DMM. The resistance reading with leads shorted together was 177.7Ω;

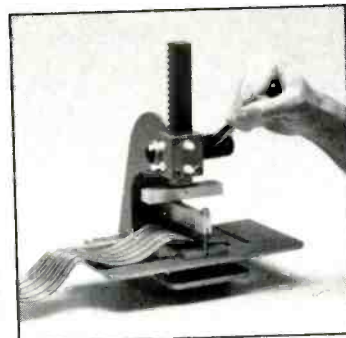

IDC BENCH ASSEMBLY PRESS: For low volume mass termination of IDC connectors on flat (ribbon) cable, choose this quick, economical 1/4 ton manual IDC Assembly Press. Select interchangeable base plates for female socket transition connectors, card edge connectors, standard DIP plugs, D-Subs, etc. Ribbon cable and strip header (IDC) cutters also available. Perfect for short run production, R&D centers, MRO's and service technicians. Model #505. Suggested retail \$139.95.



MULTI-PURPOSE WORK CENTER: Self-Centering Extra Wide Opening Head (opens to 9") is combined with our famous "split ball" Standard Base to create a versatile work station. Reversible (serrated or "V"-groove) neoprene jaw pads gently hold a variety of round or difficult to hold items with ease! Convenient Tray Base Mount (with parts wells) completes the package. Model #350. Suggested retail \$52.95.

CIRCUIT BOARD HOLDER: Eight-position rotation, tilt-angle and height adjustments plus six positive-lock positions in the vertical plane mean convenience and versatility! Spring-loaded arm holds circuit boards securely, but allows quick, easy removal and replacement. Perfect for component insertion and soldering; a must for maximum work efficiency. Model #333. Suggested retail \$49.95.

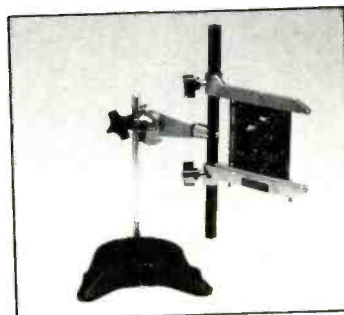

PANAVISE®

See your local electronic equipment supplier or contact PanaVise for the source nearest you.
PanaVise Products, Inc.; 2850 E. 29th Street.
Long Beach, CA 90806; (213) 595-7621.

Table 1.
DMM measurements

Condition	Defective unit	Control (functioning) unit
k Ω -open circuit	1.000 blinking	same
k Ω -short leads	153.4 Ω to 153.6 Ω	1.2 Ω to 1.3 Ω
k Ω -short leads, ohm-adjust on	150.2 Ω to 150.3 Ω	0.00 Ω
Diode continuity on	0.15 Ω , buzzer sounds	0.00 Ω , buzzer sounds
Diode continuity on, ohm-adjust on	0.00 Ω , buzzer muted	0.00 Ω , buzzer sounds
dcm range, used 1.5V battery	1.586V	1.426V
ac voltage, to wall outlet	133.2V	126.5V

Table 2.
Precision resistor checks

Reference des.	Schematic	Measured
R ₆	1.64M Ω	1.64M Ω
R ₇	164k Ω	163.5k Ω
R ₈	16.4k Ω	16.43k Ω
R ₉	1.64k Ω	1.646k Ω
R ₁₀	164 Ω	162.6 Ω

Table 3.
OVX-OVS section/surge absorber checks

Reference des.	Schematic	Measured
R ₁₂	100k Ω	100.3k Ω
R ₁₃	100k Ω	100.3k Ω
C ₁	0.22 μ f	Checked by replacement—no effect
SA	—	Checked by removal—no effect
R ₁₄	5k Ω	4.99k Ω
R ₁₅	100k Ω	100.1k Ω
TR ₁	—	Defective unit: E = -0.19V B = 1.52V C = 0V Control unit: E = 0V B = 1.38V C = 0V

Table 4.
Voltage divider checks

Reference des.	Schematic	Measured
R ₂	1.11M Ω	1.1M Ω
R ₃	101k Ω	100.6k Ω
R ₄	10k Ω	10.01k Ω
R ₅	1k Ω	1.000k Ω
C ₇	0.01 μ f	Tested by removal— No effect on shorted-lead measurement.

Table 5.
Current/voltage for resistance ranges*

Range	Spec. value	Defective unit	Control unit
200Ω	1.5V/1.4mA	1.556V/1.136mA	1.43V/1.202mA
2kΩ	0.65V/160μA	0.655V/150μA	0.649V/145μA
20kΩ	0.65V/30μA	0.665V/30μA	0.658V/30μA
200kΩ	0.65V/4μA	0.666V/3μA	0.659V/3μA to 4μA
2,000kΩ	0.65V/0.4μA	0.666V/0.000μA	0.659V/0.000μA

*Readings shown as open/short-circuit values

with ohm adjustment, the reading was 170.2Ω.

During this checkout, I put the spare fuse into the meter. The resistance value went to 200Ω. I didn't consider this reading significant because it was taken the next day, and some other component drift was suspected. Later information, however, proved that this change of resistance reading was, in fact, significant and should have been investigated. (How many times have you said to yourself, "But it looked OK"?)

Knowing that there was a defective component still in the circuit, I tried spraying coolant to isolate the problem part. I found that capacitor C₄ was sensitive to the cold: The short-circuit resistance reading went to as low as 8.9Ω when this part was cold. With C₄ replaced with a new Mylar capacitor, the resistance reading was 108.3Ω (99.9Ω with the ohm-adjust on).

At this point, the old IC was swapped back for comparison purposes and readings of 91.2Ω and 89.9Ω were obtained.

The service manual does not explain the operation of the C₄-C₅ section of the meter, so I contacted Tandy Service for further details.

Although the company could not provide details on this section (this meter was designed by an engineering staff in Japan), the symptoms were known to be related to a batch of defective 0.315A fuses that had a resistance of about 100Ω instead of the specified 1Ω to 2Ω. The actual measurement for the DVM fuse was 93.4Ω (115Ω for the spare fuse).

GUARANTEED PERFORMANCE!!



METERS



- 73 3 1/2" digit, DMM **\$67**
- 75 3 1/2" digit, DMM 99.
- 77 3 1/2" digit, DMM 128
- 8060A 4 1/2" digit-true RMA 323.
- 8062A 4 1/2" digit-true RMA 260.
- 37 Bench portable DMM **217.**
- 8010A Bench portable true RMS 255.
- 8012A Bench portable true RMS 318.
- 8050A Bench portable true RMS 349.

BECKMAN

Beckman Industrial

- DM15B 3 1/2" digit, 26 ranges, beeper **\$51.98**
- DM25L 3 1/2" digit, 29 ranges, logic probe, cap measure 94.50
- DM850 4 1/2" digit, frequency counter, data hold 207.83
- Tech300 Diode Test 113.00
- Tech330 True RMS, Diode Test 206.00
- DM73 Probe-Auto-ranging, beeper, data hold 55.00
- CC6 Clamp-on meters (measure up to 600 amps) 68.18

SCOPES



3 Years Manufacturers Warranty parts & labor

HITACHI Hitachi

Special

- V-212 20 MHZ dual trace scope **\$385**
- V-222 20 MHZ dual trace scope 550.
- V-423 40 MHZ dual trace, delayed sweep scope 795.
- V-660 60 MHZ dual trace scope 999.
- V-665 60 MHZ dual trace cursor readout scope 1245.
- V-1060 100 MHZ dual trace scope 1294.
- V-1065 100 MHZ/cursor readout scope 1544.
- V-6020 20 MHZ digital storage scope 1745.

- Beckman 9020 20 MHZ dual trace scope, component tester, delay sweep 468.

- B&K 2120 20 MHZ dual trace scope 385.

IWATSU



- DS-6411 40 MHZ digital storage scope **Call For Prices**
- DS-6612 60 MHZ digital storage scope
- SS-5706 30 MHZ 3 channel scope

- SS-5705 40 MHZ 3 channel scope **Iwatsu**
- SS-5710 60 MHZ 4 channel scope **Call For Prices**
- SS-5712 200 MHZ 4 channel scope
- SS-6122 100 MHZ 4 channel scope/CRT readout & cursor

POWER SUPPLIES

Viz

- WP-702A Dual 0-20VDC (w/ 0-200mA, dual meter) **\$190.**

- WP-703A Single 0-20VDC (w/ 0-500mA, single meter) 146.

- WP-704A Single 0-40VDC (w/ 0-250mA, single meter) 146.

- WP-705A Single 0-50VDC (w/ 0-2A, digital meter) 349.

- WP-706A Single 0-25VDC (w/ 0-4A, digital meter) 370.

- WP-707A Dual 0-25VDC (w/ 0-2A, digital meter) 465.

- WP-31A Isolation transformer 1.5KVA, 3 fixed 350VA outputs 223.78

B&K

- 1610 Power supply 0-30VDC, 0-1A **\$ 147.**
- 1630 Power supply 0-30VDC, 0-3A 220.
- 3011 Function generator 0.2 HZ - 2MHZ 205.

IC TESTER

B&K

- 560 Programmable IC tester **\$2970.**
- 541 Component tester 364.
- 550 T.T.L. IC comparator 364.
- 552 CMOS I.C. comparator 364.

SOLDERING SUPPLIES

Ungar



- UTC 100 Temperature controlled soldering system **\$67**

- 4024 De-soldering service station 414.
- 9000 Temperature controlled soldering station 208.

- 6970 HD Heat gun (gives 1000 watts) 72.
- 1095 Heat gun (gives 1000 watts) 35.
- 1100 Soldering gun 100/140 watts 20.

WELLER

- WTCPR Control output soldering station **\$119.**
- 8200 All purpose soldering gun 21.
- D550 28.58

Kester solder and multicore solder available CALL!



"I GUARANTEE YOUR SATISFACTION!
For 43 years professionals have counted on KELVIN, for the lowest prices and immediate delivery, from our huge inventory. Count on KELVIN!"

Lisa S. Hadar
Executive V.P., C.P.A.

WE CARRY
Panavise, Xcelite Tools, Vaco Tools, X-Acto, Kester Solder, Sellstrom Safety Equipment

- Electronic Parts
- Electrical Parts
- Large Selection of State of the Art Educational Kits.

Not Responsible For Typographical Errors.

KELVIN

FREE CATALOG

1-800-645-9212

ELECTRONICS 7 FAIRCHILD AVE., PLAINVIEW, N.Y. 11803 (516)349-7620 FAX:516-349-7830

Circle (12) on Reply Card

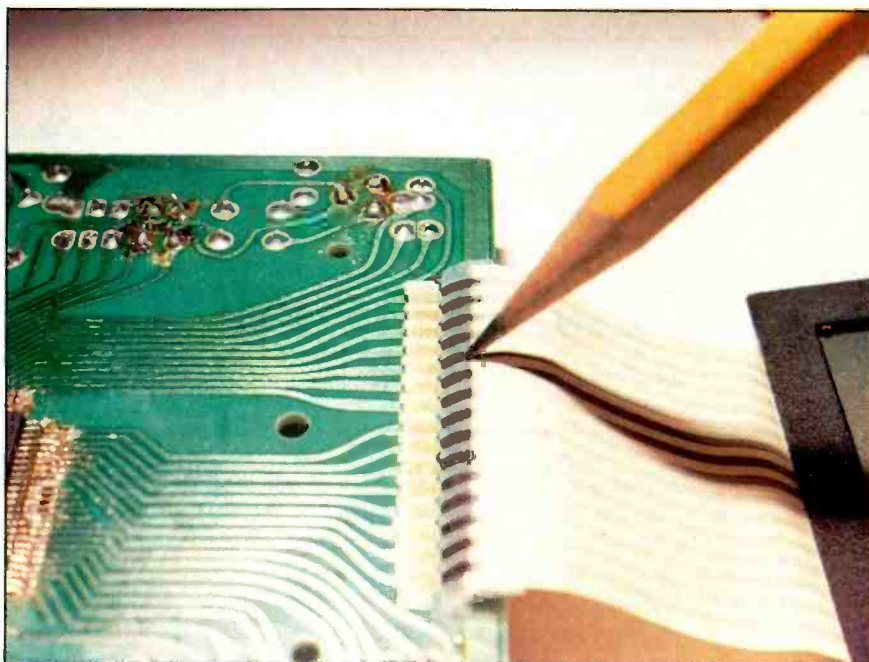

Figure 3. A lead pencil can be used to repair LCD traces.

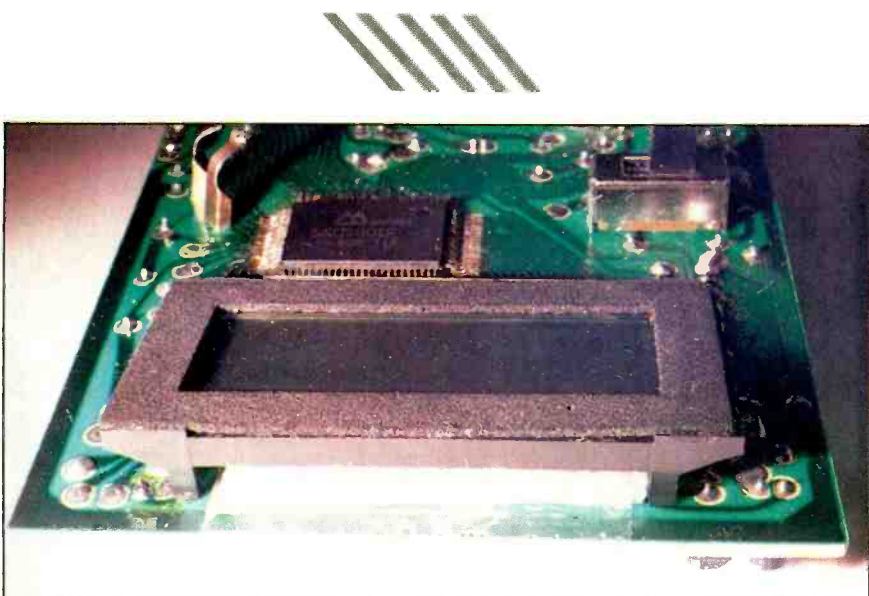
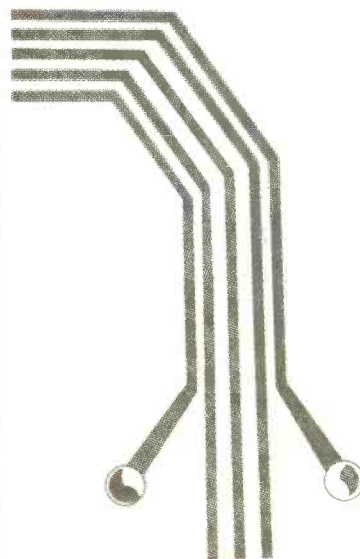

Figure 4. Foam placed between the LCD display and the display connector tape will enhance connections to the PC card when the display is screwed down.

Replacing the original with a good fuse resulted in a shorted test-lead reading of 1.1Ω (0.00Ω with the ohm-adjust on).

During final repairs, I encountered problems with the display and with other meter functions. The display/connector tape separated from the printed-circuit card, and some traces opened in the connector tape. I repaired the connections by rubbing them with a lead pencil (Figure 3). Proper connections to the PC card were enhanced by foam material between the display and the connection tape. The foam would press on the PC-card connections when the dis-

play was screwed to the PC card (Figure 4).

Cold solder joints and solder bridges resulted in missing display segments. I used the repair manual to pinpoint the problem connections. I also encountered two other problems on the way to completing this repair. The first was the ac current/ac voltage ranges, which did not read zero with the test leads shorted. This was caused by a solder bridge in the ac/dc converter section. The second problem was voltage overranges that occurred when more than 20V (ac or dc) was measured. These overranges were

caused by an open circuit in the voltage divider network.

Troubleshooting techniques

In this repair, as in any repair attempt, the following steps should be performed:

1. Determine the circumstances surrounding the problem. Did it fail after a power surge or brownout, was it dropped, etc.
2. Confirm the failure symptoms.
3. Visually examine the unit for previous repair attempts, missing parts, cut connections, solder flux or parts tacked in place.
4. Determine the possible areas where the problem may be coming from. (Did the visual examination reveal any charred circuit areas?) Check out each circuit section. Use manufacturer service data/schematics when available. If possible, compare test readings against a known-good unit.
5. Always investigate each anomalous condition. For example, I could have saved time if I had investigated the change in the meter reading when the spare fuse was installed.
6. After repairs are attempted, check all unit functions to verify that a new problem has not surfaced.
7. If problems persist, contact the manufacturer for assistance.
8. Keep notes of all your efforts during the repair. They may be useful for reference during the current repair and during future repairs if the same problem is seen again.

ES&T

SYMCURE/ Troubleshooting Tips guidelines

ES&T is now paying \$60 per page (six different cases of symptoms and their solutions) for accepted Symcure submissions.

The term *Symcure* is a contraction of two words: symptom/cure. Problems that are published in the Symcure department are those that have occurred more than once.

This is the kind of problem you can solve without even a second thought because you've already seen so many of that particular brand and model of set with those symptoms; in almost every case, it will be the same component that fails or the same solder joint that opens.

It is preferred that you submit six or seven symptoms and cures for a single TV model.

ES&T is also paying \$25 per item for accepted Troubleshooting Tips.

A Troubleshooting Tip describes a procedure used to diagnose, isolate and correct an actual instance of a specific problem in a specific piece of equipment. Its value, however, lies in the general methods described.

A good Troubleshooting Tip has the following elements:

- It should be a relatively uncommon problem.
- The diagnosis and repair should not be obvious and should present something of a challenge to a competent technician.
- It should include a detailed, step-by-step description of why you suspected the cause of the problem and how you confirmed your suspicions—anything that caused you to follow a false trail also should be included.
- It should describe how the repair was performed and any precautions about the possibility of damage to the set or injury to the servicer.

For Sycures and Troubleshooting Tips, please also include:

- the manufacturer's name;
- the model and chassis number;
- the Sams Photofact number; and

• a sketch of the schematic area where the fault was found. (Include a major component such as a transformer or transistor to provide a landmark for the ES&T staff.)

This book can save your company a lot of money.



It's free, too.

GENSTAR
RENTAL ELECTRONICS, INC.

(800) 227-8409

In California (800) 331-3440

This coupon will get you the information you need . . . fast!

- Send me a free Rental Catalog. The equipment I'm most interested in is: _____
- Include a catalog of like new products you have for sale. _____
- Call me immediately at: _____

NAME _____ TITLE _____

ORGANIZATION _____

ADDRESS _____ MAIL STOP _____

CITY/STATE/ZIP _____

TELEPHONE _____

Complete coupon and mail to: Genstar Rental Electronics, Inc, 6307 De Soto Ave., Suite J, Woodland Hills, CA 91367 EST 6/88

©Genstar Rental Electronics, Inc. 1987

Circle (34) on Reply Card

June 1988 *Electronic Servicing & Technology* 47

What do you know about electronics?

Hall-controlled motors

By Sam Wilson, CET

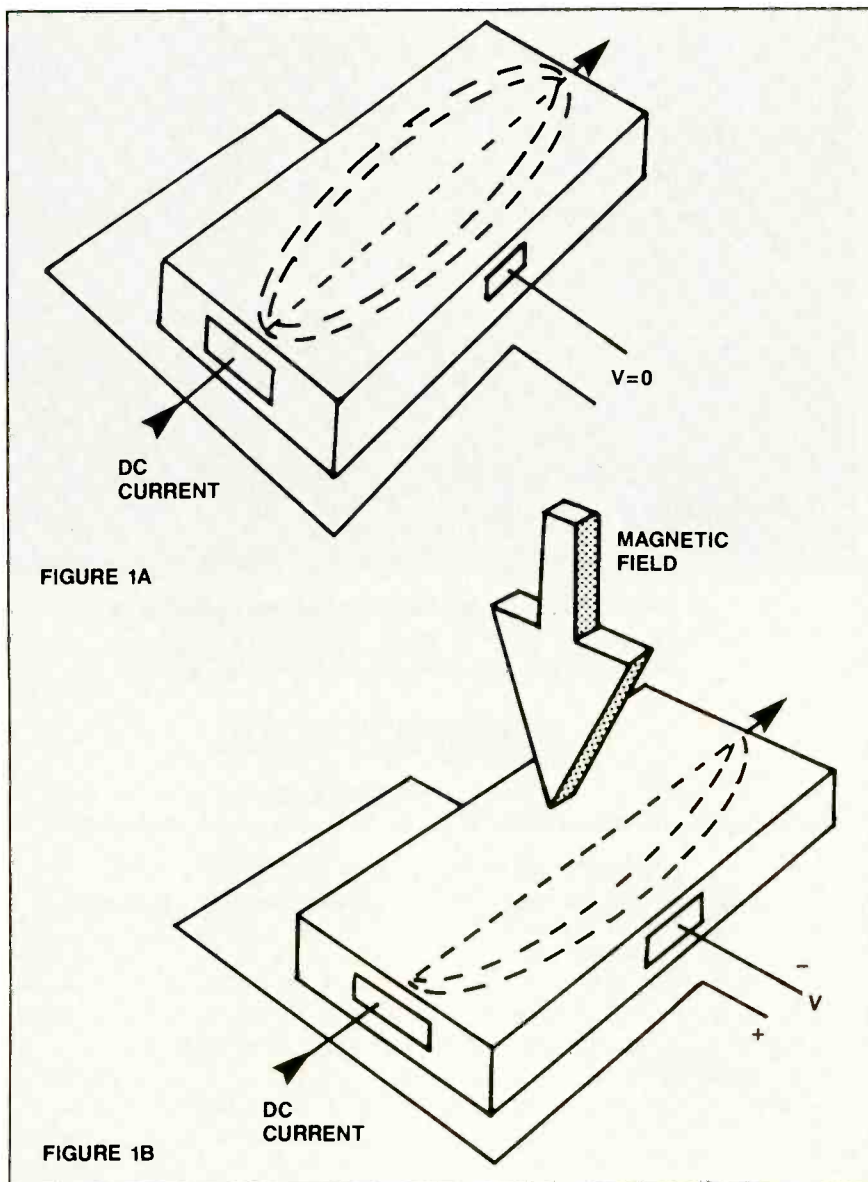

Figure 1. In the Hall device shown in Figure 1A, an electron current is flowing through a small semiconductor slab. The broken lines show that the electrons spread out because like charges repel. When a transverse magnetic field is introduced, as represented in Figure 1B, the electrons crowd to one side.

In previous articles, I discussed the Hall effect. I also discussed the phase-locked loop (PLL). Now I'll put those subjects together to show how motor speed can be controlled using those two concepts.

It's been a while since those subjects were covered, so I'll start with a short technical review.

Basic theories

The basic concept of the Hall device is shown in Figure 1. In Figure 1A, an electron current is flowing through a small semiconductor slab. The broken lines show that the electrons spread out because like charges repel. There is no output voltage because the electrons are equally distributed between the dc electrodes.

When a transverse magnetic field is introduced, as represented in Figure 1B, the electrons crowd to one side. This effect is similar to electron deflection in a picture tube.

In reality, the flow of the electrons is somewhat more complicated than shown in the illustration. When an electron moves through a magnetic field, its magnetic field reacts with the external magnetic field to produce a corkscrew motion. This motion occurs because the force on the electron is the vector sum of the forces produced by the motion of the electron and the magnetic resultant force.

Showing the corkscrew motion in the illustration of Figure 1A would make it unnecessarily complicated. Anyway, the overall result would be the same—a crowding of the electrons on one edge. The overall result is a dc voltage at the output of the Hall device.

Wilson is the electronics theory consultant for ES&T.



Figure 2 illustrates the basic idea behind the PLL. Two frequencies are introduced to the frequency and phase comparator (\emptyset). One is a fixed frequency (f_1) from a precise frequency generator. The second frequency (f_2) comes from a voltage-controlled oscillator (VCO).

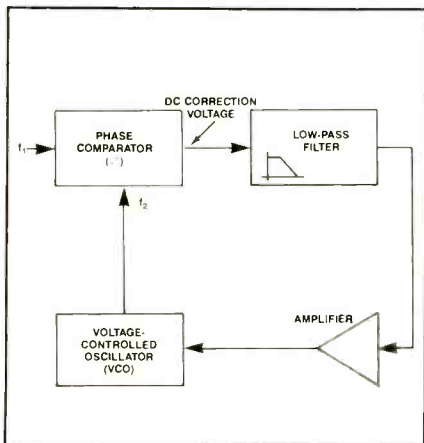

Figure 2. In a PLL, two frequencies (f_1 and f_2) are introduced to the frequency and phase comparator (\emptyset). If the two input signals are not the same, a positive or negative correction voltage appears at the output of the comparator.

If the two input signals are the same in frequency and phase, the output correction voltage is 0V. When the frequencies are not the same, a positive or negative correction voltage appears at the output of the comparator.

The low-pass filter eliminates both f_1 and f_2 , so only the dc correction voltage is delivered to the amplifier. This dc amplifier is optional, so you won't see it in every drawing of a PLL.

The correction voltage is delivered to the voltage-controlled oscillator. If f_1

equals f_2 , the correction voltage is 0V (because there is no need for correction). Of course, the 0V correction voltage makes no change in oscillator frequency. If f_1 is not equal to f_2 , the dc correction voltage will change the VCO frequency until those frequencies match. The result is that the VCO output frequency is locked to the reference frequency.

Combining the theories

In Figure 3, a Hall-controlled motor has been introduced into the loop in place of the VCO. This device consists of a dc motor mechanically connected to a rotating drum with two permanent magnets (M_1 and M_2) attached 180° from each other.

When a permanent magnet passes close to one of the Hall devices (H_1 or H_2), a pulse of voltage occurs at the output. Because of the way the magnets and Hall devices are positioned, there are four pulses out of the OR circuit for each 360° rotation of the drum. So, if the drum speed is 900RPM, the output of the OR circuit is:

$$\frac{900 \text{ revolutions}}{\text{minute}} \times \frac{1 \text{ minute}}{60 \text{ seconds}} \times$$

$$4 \frac{\text{pulses}}{\text{rev.}} = 60 \frac{\text{pulses}}{\text{second}}$$

The amplifier delivers a dc voltage to operate the dc motor. In the equation above, the frequency of the pulses delivered to the phase comparator would be 60 pulses/second if the motor speed is correct.

If the motor speed is too fast or too slow, there will be a positive or negative correction voltage delivered to the am-

VCR IDLER TIRES



Now you can do VCR repairs faster and easier than ever before. **Parts Express** is now offering the most comprehensive idler tire kit available. With this kit in your stock room you can do over 90% of idler assembly repair jobs without waiting for parts deliveries.



The kit includes a **FREE** cross-reference listing over 80 manufacturer assembly numbers and over 200 model numbers. 150 tires total, 10 each of 15 different sizes in a high quality storage case with separate compartments for each size. Worth over \$400 retail value.

FREE
cross-reference
included

\$55.00

#400-900

VCR IDLER ASSEMBLIES



Part #	Replacement for	(1-9)	(10-up)
430-010	Sharp NIDL0006	4.15	3.70
430-020	Sharp NIDL0005	4.35	3.90
430-030	Sharp NPLY-V0051	4.15	3.70
430-050	Pana VXPO329	1.40	.95
430-052	Pana VXPO344	1.40	.95
430-055	Pana VXPO401	1.95	1.55
430-060	Pana VXPO521	4.50	3.90
430-100	Fisher 4204-00300	7.80	6.90
430-105	Fisher 4804-00100	1.50	1.25
430-110	Fisher 4904-00900	7.50	6.75
430-120	RCA 164113	3.75	2.95
430-125	RCA 150614	3.95	3.25
430-130	HIT 6413111	5.20	4.65

FREE
CATALOG



Parts Express
International Inc.

CALL TOLL FREE
1-800-338-0531

340 E. First St., Dayton OH 45402
Local—1-513-222-0173

Circle (19) on Reply Card

plifier. That correction voltage, in turn, will result in a change of motor speed until the motor turns at exactly 900RPM.

If a divide-by-two circuit is added to

the circuit, as shown by the colored lines, the motor speed will double. The reason is that it is necessary to get 120 pulses per second out of the OR circuit. Then, when the 120 pulses/second are

divided by 2, the resulting 60 pulses/second will match f_1 .

If a divide-by-two circuit is added at the input, as shown in Figure 4, the motor speed will be reduced to half the value given for Figure 3. At half speed, the output of the OR circuit is 30 pulses/second in order to match the input (f_1/f_2) to the phase comparator.

If a divide-by-two circuit is used at f_1 and a divide-by-three circuit is used at f_2 (see the colored lines), the motor speed will be $3/2$ the original value, or $(3/2)900=1,350\text{RPM}$.

Programmable dividers also can be used to get a wide range of speeds. A microprocessor can be used to set the programmable dividers. That way, the Hall-controlled motor speed is set by a microprocessor keyboard.

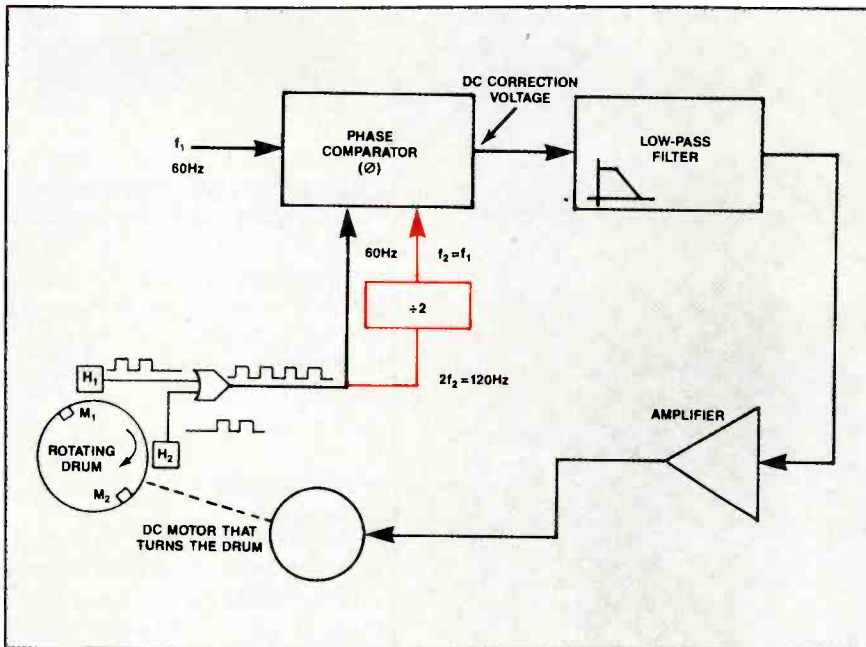

Figure 3. A Hall-controlled motor can be introduced into the loop in place of the VCO. If the motor speed is too fast or too slow, there will be a positive or negative correction voltage delivered to the amplifier. That, in turn, will result in a change of motor speed. The motor speed can be doubled by a divide-by-two circuit, shown by the colored lines.

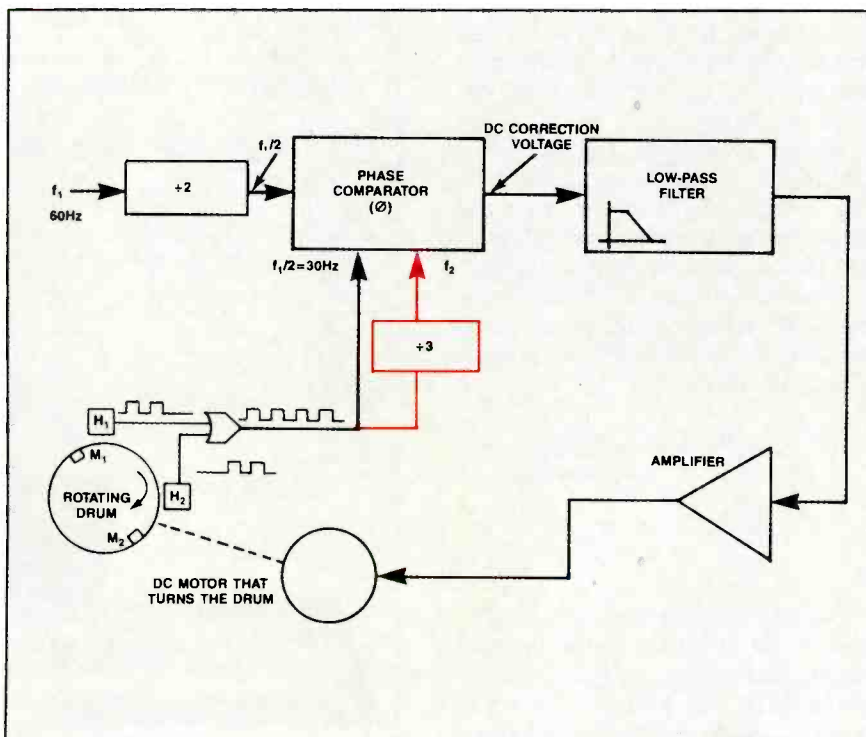

Figure 4. If a divide-by-two circuit is added at the input the motor speed will be reduced to half the value given for Figure 3. If a divide-by-two circuit is used at f_1 and a divide-by-three circuit is used at f_2 (see the colored lines), the motor speed will be $3/2$ the original value.

Another way to measure transformer imbalance?

Delbert S. Shafer of Warren, OH, has written to tell me about another way to determine imbalance in circuits. He adjusts the pot until the lamp filaments just barely glow. This is useful on pulses as short as one cycle (16ms). He uses this lamp on SCR-controlled resistance heating and motor-speed controls, the output of PA systems, the output of full-wave rectifiers (to see if one leg is leaking) and triac-controlled equipment. (His circuit is shown in Figure 5.)

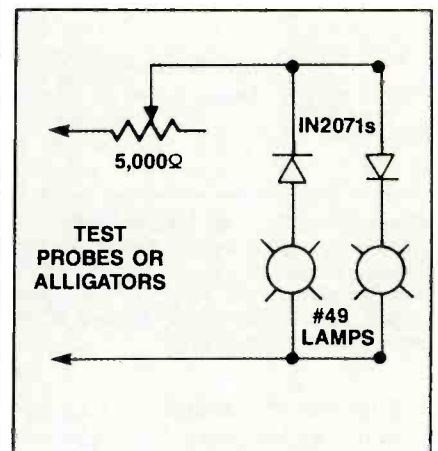

Figure 5. This figure shows another way to determine imbalance in circuits. The pot is adjusted until the lamp filaments just barely glow. This is useful on pulses as short as one cycle (16ms).

If any other readers have ideas for home-built test equipment and troubleshooting ideas, send them in so we can share them.

ES&T

Quiz answers

Questions are on page 18.

1. In any order:

Electrostatic: A voltage can be generated by rubbing two dissimilar insulating materials together.

Chemical: A voltage can be created by immersing two dissimilar conductors (or semiconductors) in an acid or alkaline solution.

Heat (thermal): A voltage is generated when the junction of two dissimilar metals is heated.

Light: A voltage can be generated when certain materials are exposed to light.

Pressure (piezoelectric): Some crystalline materials generate a voltage when under pressure.

Electromechanical: Voltage is generated

any time a conductor is moved through a magnetic field.

2. 0.0015321A. The resistance value is $3.33k\Omega \pm 2\%$. Maximum current flows when the resistance is at its lowest allowable value. (The question asks for the maximum current, not the current you can measure. The answer is OK for calculator accuracy.)

3. D—None of the above. For two reasons: The manufacturers say you should not return components to the board, and you should *never* epoxy a component to a board. (The epoxy is used during the manufacturing procedure.)

4. No. Both lamps are operating at their rated value. If the resistor can dissipate the required power, the circuit is OK as is.

5. 160Hz. One cycle will be displayed

if the input frequency is 40Hz. (That's 1/0.025 seconds.) You need a frequency that is four times higher to display four cycles in the same amount of time.

6. B—point y. The greatest rate of change of current occurs as the sine-wave current passes through zero.

7. An electret. It is the dual of a permanent magnet that has a permanent magnetic field.

8. No. The power rating is set by the manufacturer.

9. No. A fuse is blown by current, not voltage.

10. Yes. The voltage across L is equal to IX_L . If you double the current, you will double the voltage as long as X_L does not change.

ES&T

Weller® PPS. The unique answer to SMD re-work.

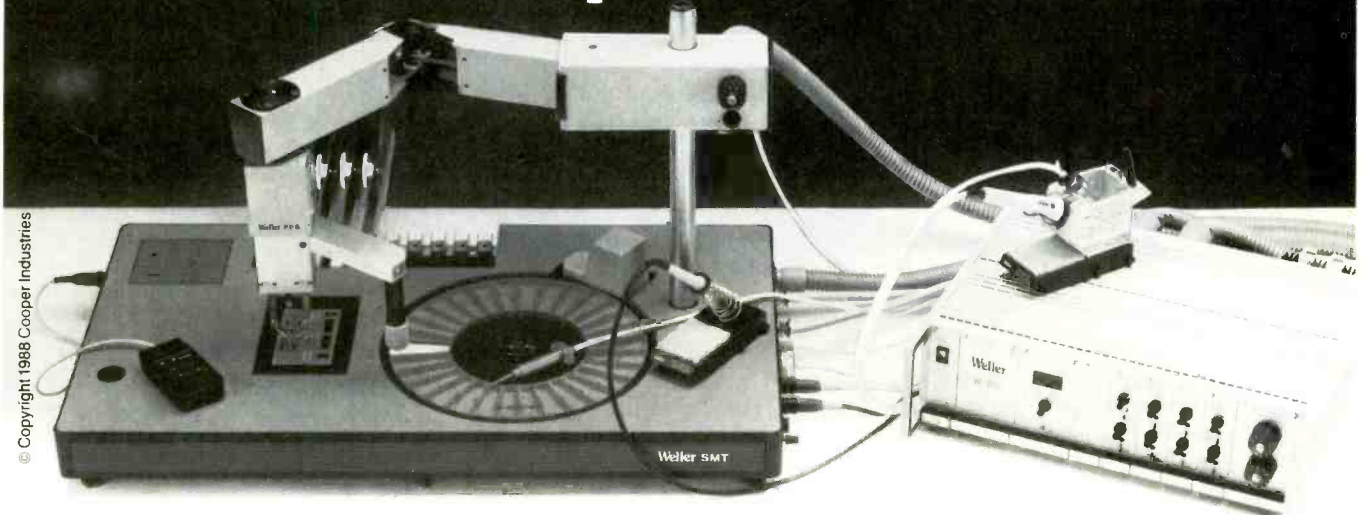

© Copyright 1988 Cooper Industries

Weller, the undisputed leader in soldering technology, is proud to introduce a unique piece of equipment, specifically designed for the repair, re-work and prototyping of circuit boards with lead-less and hybrid components and also for small production runs.

The Weller Pick-Place-Solder system is a self contained manual work station for the application of glue or solder paste and for the removal, positioning, soldering and desoldering of SMD's by means of temperature controlled inert gas. Call today for the full, state-of-the-art details.

CooperTools

The difference between work and workmanship.

BREWER-TITCHENER™ CAMPBELL COVERT CRESCENT LUFKIN MERRILL NICHOLSON PLUMB H.K. PORTER TURNER WELLER WIRE-WRAP WISS XCELITE®
CooperTools PO Box 728 Apex NC, 27502 USA Tel (919) 362-7510 Telex 579497
A division of Cooper Industries

Circle (18) on Reply Card

A build-it-yourself signal injector

By Gregory D. Lettera

This handy little gadget can help you track down a defective amplifier—and you can build it yourself.



If you need a simple tool for tracking down defective amplifiers, try out this square-wave signal injector. It's smaller than a pen or matchbox enclosure, and it's portable, which makes it ideal for bench or field work.

This simple multivibrator circuit has an approximate frequency range of 1kHz to 10kHz with a maximum output of about 1.4V peak-to-peak. The amplitude can be reduced by varying R_4 (see Figure 1).

The waveform (see Figure 2) is rich in harmonics. That gives it a wide fre-

quency spectrum. The duty cycle can be changed by varying the resistance ratio at R_1 . The frequency range can be altered by reducing or increasing the resistance value of R_2 and the capacitance value of C_1 .

R_3 sets the probe to 600 Ω of output resistance. Isolation protection can be increased by using a ceramic capacitor of 0.1 μ F. However, this change in capacitance will alter the rise time of the square-wave form and reduce the harmonic content.

The multivibrator is flexible and inexpensive to build. I built mine for less than \$6 using parts from a local electronics supply house.

Parts and specifications:

IC = LM 3909
 V_1 = 1.5V battery (AA)
 C_1 = 0.15 μ F at 5V Wdc
 R_1 = 10k Ω potentiometer (0.25W)
 R_2 = 10k Ω potentiometer (0.25W)
 R_3 = 600 Ω (0.25W)
 R_4 = 10k Ω potentiometer (0.25W)
Frequency range = 1kHz to 10kHz
Harmonic spectrum = 1kHz to 11kHz
Output voltage = 1.4V to 0V

Lettera is an electronics lab technician at the New England Institute of Technology.

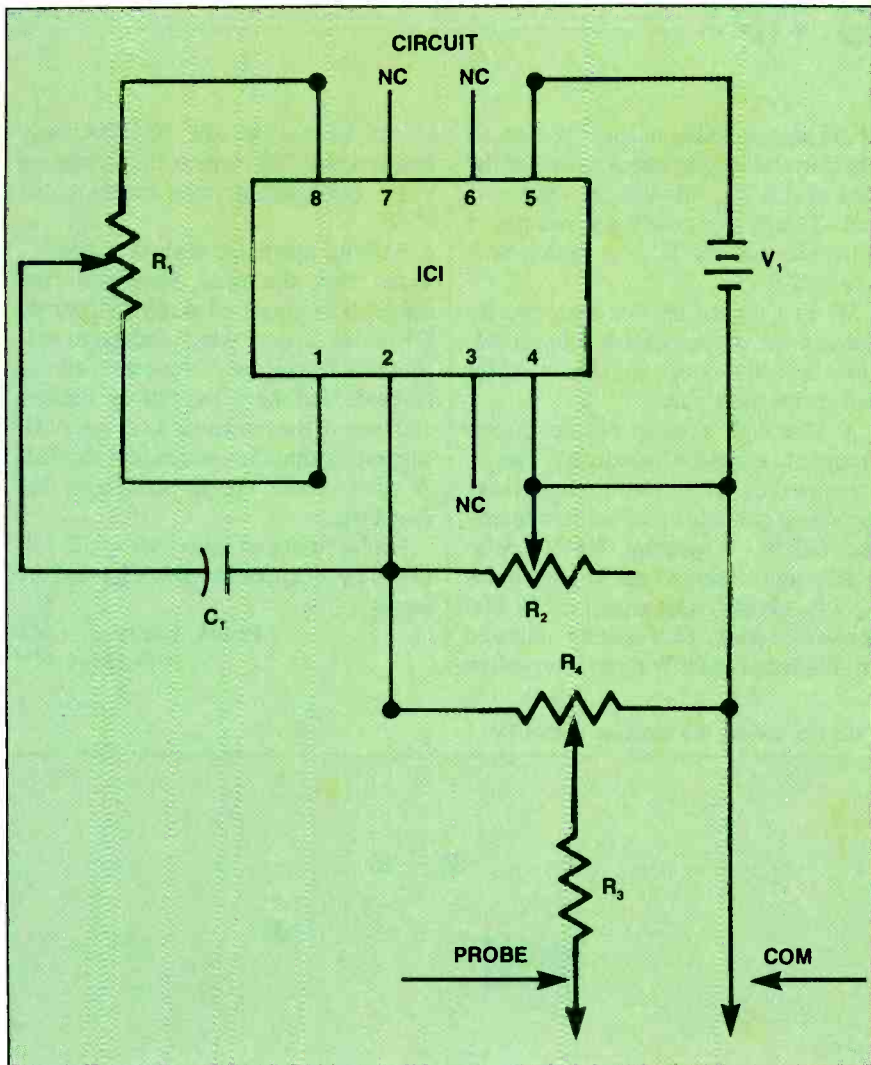

Figure 1. This simple, square-wave signal injector can help you track down defective amplifiers.

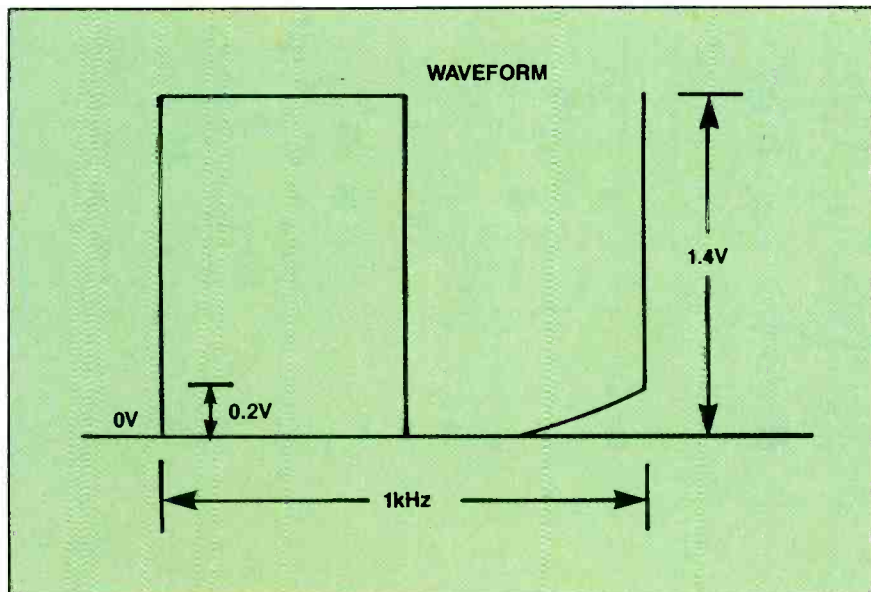

Figure 2. The waveform produced is rich in harmonics, with a wide frequency spectrum.

HITACHI SCOPES

15-25% Discount



V1060
100MHz
\$1285

V660 60MHz Dual Trace \$899
V422 40MHz Dual Trace \$699
V212 20MHz Dual Trace \$379

ELENCO PRODUCTS AT DISCOUNT PRICES!



\$498
MO-1252

Scopes

Delayed Sweep 12KV HV, More
MO-1252 35MHz Dual Trace \$498
MO-1251 20MHz Dual Trace \$349
w/ Two 1x, 10x 100MHz probes, manual
S-3000 10MHz fully calibrated \$239

GF-8016 Function Generator with Freq. Counter



\$239.95

Sine, Square, Triangle
Pulse, Ramp, .2 to 2MHz
Frequency .1 thru 10MHz

GF-8015 without Freq. Meter \$179

Digital Triple Power Supply



Model XP-765 **\$239.95**

0-20V @ 1A
0-20V @ 1A
5V @ 5A

Fully Regulated, Short Circuit Protected
with 2 Limit Cont. 3 Separate Supplies

XP-660 w/ Analog Meters \$169.95

Color Convergence Generator



SG-200
\$69.95

Finest in the industry
10 rock steady patterns

Digital LCR Meter

\$138.95

Model
LC-1800

Measures
Inductors,
Capacitors,
Resistors



Multimeter with Cap. and Trans. Tester

\$59.95

Model
CM-1500A

8 Functions
with Case



C&S Sales Inc., 1245 Rosewood
Deerfield, IL 60015 (312) 541-0710
800-292-7711 ASK FOR CATALOG

15 Day Money Back Guarantee
2 Year Limited Guarantee
Add 5% for Postage (\$10 max)
IL Res., 7% Tax



ES&T

Circle (11) on Reply Card

Troubleshooting tips

Dark screen RCA CTC 110 (Photofact 2033)

The problem with this TV was that the screen was black, but still had good sound. When I turned on the set, I heard the normal rushing sound that indicates high voltage is present. Turning up the screen control revealed that there was a blank raster with full deflection.

This symptom pointed to a problem in the video circuit. Because the heart of the video circuit in this set is U701, the luma/chroma IC (see Figure 1), I decided to scope the inputs to U701 (Y-pin 27 and C-pin 3). The signals at these points were normal. Next, I checked the output waveforms at pins 20, 21 and 22.

There was no video at these points, so I performed voltage checks at all of the pins of this IC. All voltages were normal. This set of conditions led me to conclude that the IC was faulty, so I replaced it.

When I turned the set back on, instead of the proper picture I expected, I saw the same symptoms the set exhibited in the first place.

A thorough review of the circuit brought to mind the "sandcastle" waveform used by RCA. This timing/blanking signal is made up of vertical blanking (R710), horizontal IHVT pulse (R712) and a horizontal keying pulse (Q801). Scoping this signal at TP 806 showed no peak. This reading indicated an absence of sync. Without this portion

of the sandcastle, the IC effectively blanked the CRT screen by preventing video information from reaching the CRT.

Probing upstream with the scope, I found that the sync waveform that should have appeared at the collector of Q303 was absent, which led me to suspect that transistor. Voltmeter readings revealed that the voltage at the emitter and base of the transistor were identical, suggesting that this device was shorted. A curve tracer check confirmed that diagnosis.

Replacement of transistor Q303 followed by a proper setup completed the repair.

Frank Comisso, CET
Buffalo, NY

Figure 1. Replacing U701, the luma/chroma IC, did not correct the problem in this TV.

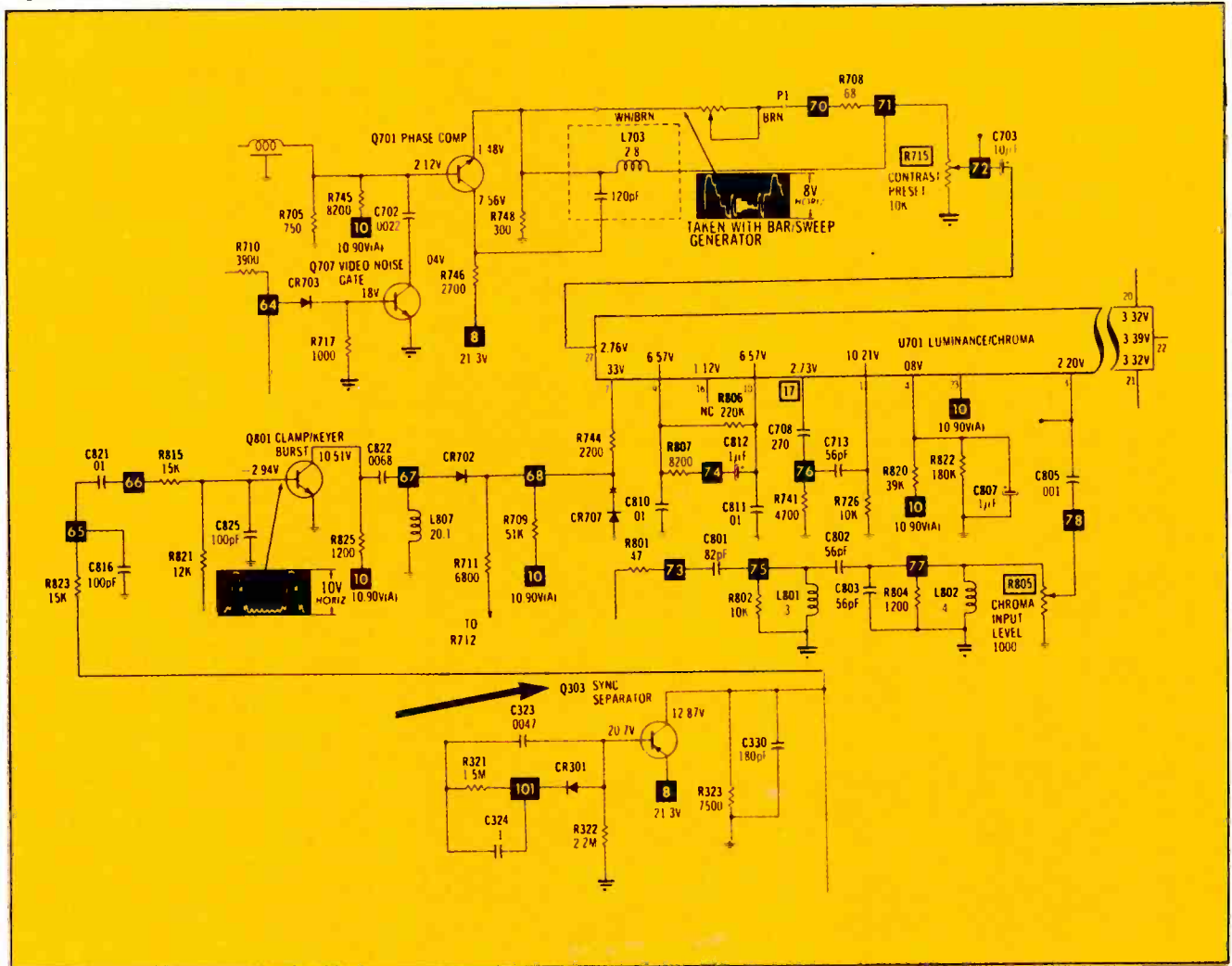

**VCR stays in PAUSE/STILL
GE VCR Model 9-7115**

The customer who brought in this VCR complained that when a cassette was inserted into the VCR and the play button was pressed, the tape would load, but the unit would immediately go into the PAUSE/STILL mode. Pressing the PAUSE/STILL button had no effect. SCAN FORWARD and REVERSE worked normally, but when those buttons were released, the VCR went right back to PAUSE STILL.

I suspected problems on the timer/operation board and proceeded to check the input lines related to PAUSE/STILL operation. Even after the data 6 and scan 4 ports of IC7501 were isolated, the problem remained. I convinced myself that the culprit had to be the timer microprocessor. Well, 64 desoldered and soldered pins later, the new IC gave

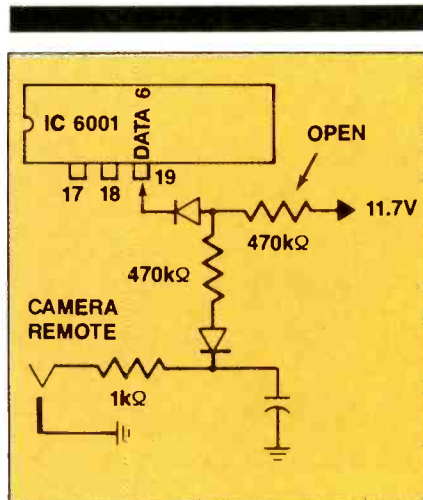

Figure 1. An open R6024 caused the voltage at pin 19 to be so low that the unit went into PAUSE mode.

me no change of symptoms.

I discussed the problem with a fellow technician, who casually mentioned that this mode of operation sounded like the operation of camcorders when they are loaded for recording. Bingo! Something clicked, and I realized that I had completely overlooked the camera remote line. Checking pin 19 (see Figure 1), I found that the data 6 line of the main micro, IC6001, showed about 1.8V. Normal voltage at that port is 3.1V. After desoldering pin 19, I turned the unit on and it played normally. Something was causing the voltage at that pin to be low enough to put the unit in PAUSE.

A few multimeter checks at points in the vicinity of Pin 19 revealed an open 470kΩ R6024, which feeds B+ to pin 19. Replacement of this resistor restored normal operation.

Ronald J. Patch
Bismark, ND

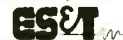

**PRB...
OFFERS A
COMPLETE
SELECTION OF:**

- VCR REPLACEMENT BELTS
- VIDEO CLUTCH TIRES

PROJECTOR-RECORDER BELT has the Replacement Belts and Video Clutch Tires you want. PLUS...

- Our new and improved MEASUR-A-BELT GUIDE helps you find the PRB Replacement Belt you need... fast.
- There's no need to disassemble and assemble your VCR clutch drive... just snap off the old... then snap on the new PRB tire.

PRB has the belts and tires you need... and the system that helps you find your replacement belts and clutch tires easily and fast for a profitable return on every sale.

PRB Belts... Made in the U.S.A.

For more information call toll free...

National 1-800-558-9572

In Wisconsin 1-800-242-9553

Business Number 1-414-473-2151

TLX 4994411 PRB USA

In Canada call collect: 1-613-225-5003.

FAX: 414/473-4727



PROJECTOR-RECORDER BELT CORP.
P.O. Box 176 Whitewater, Wisconsin 53190

Circle (20) on Reply Card

GOT A PROBLEM?

Like testing 16 logic lines simultaneously, economically?

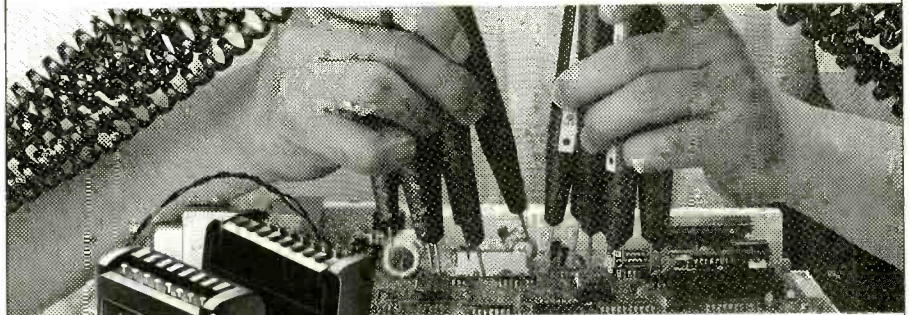

Get The Solution:

- The AR-80LM Logic Monitor. Like 16 20 MHz logic probes.
- TTL and CMOS. Even pulse memory to catch that elusive glitch.
- ARI's AR-80LM. Because you deserve the best.

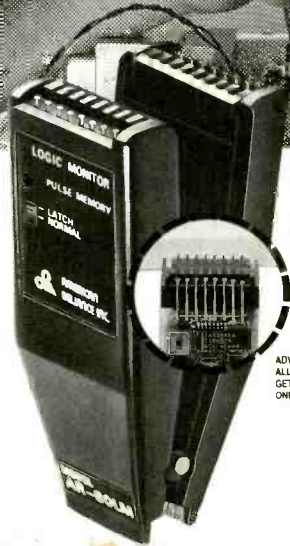

ADVANCED CUSTOM IC DESIGN
ALLOWS USE 10-20 MHz - LIKE
GETTING 16 LOGIC PROBES IN
ONE COMPACT PACKAGE



AMERICAN RELIANCE INC.
VALUE BEYOND MEASURE

9241 E. VALLEY BLVD, ROSEMEAD, CA 91770
TEL: (818) 287-8400, (800) 654-9838

ARI manufactures a complete line of electronic test equipment, including EPROM, EEPROM, and PLD programmers. IC testers, Cable testers, DPMS, DMMs, and Logic testing devices. Call or write today for your free Brochure.

Circle (21) on Reply Card

Products

PC diagnostic board

The Blue-Magic diagnostic board plugs into any slot of a PC and displays located errors on the monitor. The board can be purchased alone or with a portable printer. Exercise and monitoring operations, including self test, are carried out without keyboarding. The board tests BIOS read-only memory; the 8253 programmable interval timer (all three channels); the 8237 DMA chip (all four channels); the 8259 programmable interrupt controller (all eight channels); all lines of the 8255 PIO controller as three 8-bit ports; all RAM of the motherboard and installed memory cards; the keyboard-interface circuitry on the motherboard; and LPT1, LPT2, COM1 and COM2 and their support circuitry on the motherboard.

Circle (75) on Reply Card

Voltage detector

The model VH-600 Volt-Hound non-contact voltage detector from *A.W. Sperry Instruments* detects 100Vac to 600Vac with respect to ground. If the tip is placed near a live wire, the unit gives audible and visual indications. The hand-held unit weighs 1 ounce.

Circle (76) on Reply Card

Vision aid

The Stereoptic Magnifier vision aid from *Edroy Products* provides up to 48 square inches of distortion-free, illuminated viewing area and maintains complete depth of field through all focal



distances. The base provides stability in extending the lens assembly up to 19 inches from the rear of the base and up to 13 inches high. The lens angle is adjustable. Two models are available, each with one or two lenses and with or without a lamp.

Circle (77) on Reply Card

Desoldering stations

Plato Products has introduced three products that meet DOD standards. The V-985 and V-185SF fully grounded desoldering stations meet military and

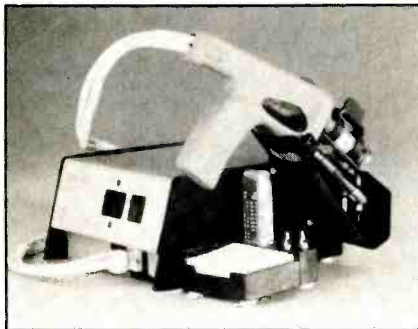

navy specifications for transient voltage of 2mV peak-to-peak. The V-985 shop air model is a spike-free station equipped with circuitry to prevent transient voltages at the tip. The V-185SF, a spike-free station with an internal generator, features a quick-cleaning solder collector and non-clogging tip and conduit.

Plato has also introduced permanently static-dissipative products that meet DOD and Mil specs. These products include flux and liquid dispensers, lead cutters and desoldering wick in a variety of sizes.

Circle (78) on Reply Card

Wire-wrapping gun

The OK-730 hand-held, air logic wire-wrapping gun from *O.K. Industries* has a triggerless "thumb sensor" that eliminates muscle fatigue. The gun is used with the ALC-730 Air Logic Control Unit. A small amount of air is released constantly through the thumb-controlled air hole. When the thumb blocks the hole, the air flow switches to engage the air motor and rotate the standard bit and sleeve.

Circle (79) on Reply Card

Delayed-sweep scope

The *Phillips PM 3070* 100MHz, delayed-sweep oscilloscope is a dual timebase model that has full cursor measurement capabilities in the time and amplitude axes. The scope features automatic display set-ups, two input channels and a third channel (Trigger-view). A zoom function allows a section of the measured signal to be pinpointed by the cursors and expanded to the width of the screen. Measurement

calculations automatically include the probefactors, magnifier and timebase used.

Circle (80) on Reply Card

Wire locator

The model 50B wire locator from *Contact East* is designed to locate the path and depth of buried telephone and service wire and to locate the end of a cut or open wire. It operates on dead and active lines and will locate conductors 3-foot deep. The unit includes a lightweight, solid-state transmitter and a receiver.

Circle (81) on Reply Card

Write-protect device

Director Technologies has introduced the Disk Defender, a hardware write-protect device for fixed Winchester disks. The circuit board plugs into any IBM XT, AT or compatible. The device permits protection of a portion of the disk while allowing operation of full read and write functions on the rest of the disk. A control box provides full or partial protection. The device is transparent to and operates independently of software and can be used with multiple operating systems on one disk.

Circle (82) on Reply Card

PC maintenance and repair kit

The JTK-39C "Blue Max" maintenance and repair kit from *Jensen* is designed for PC workstation assembly, cable repair, routine removal and installation of circuit boards and disk drives. The kit includes a selection of



tools, a soldering iron, a hex key set, insertion/extraction and IC inserter tools, a pen light, an adjusting tool and more. The case has room for an optional probe meter.

Circle (83) on Reply Card

Anti-static cleaner

Staticide anti-static cleaner from *ACL* cleans and controls static electricity on table tops, anti-static mats and work stations. It leaves no film, is non-abrasive and non-flammable.

Circle (84) on Reply Card

Foam swabs

The PURSWAB line of textured foam swabs has been introduced by *Hardwood Products*. The swabs are available with foam or foam-over-cotton tips with polypropylene or wood shafts. A variety of sizes and shapes are available.

Circle (85) on Reply Card

Computer carrying case

Chicago Case Company has introduced a foam-lined carrying case for transporting lap-top computers and portable printers. The case is made of polyethylene and features a removable top with a compact brief case for paper storage.

Circle (86) on Reply Card

Chassis holders/mounts

PanaVise Products has introduced two chassis holder/mounts for load capacities of more than 100 pounds and width

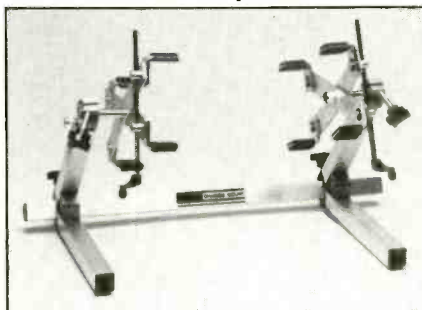

capacities of up to 18 inches. The devices are made of 1¼-inch square aluminum alloy tubing and allow a pivot-center height of 9 inches from the work surface. For safety, a positive lock detent is visible while the chassis heads are rotated, and a visual indicator shows when the safety latch is engaged. The all-metal friction brakes allow for either left- or right-hand operation.

Circle (87) on Reply Card

Industrial test lead set

John Fluke Mfg. has introduced the TL20 industrial test lead set. The set features heat-resistant test leads and interchangeable alligator clips (with retractable jaws) and stainless steel, needle-point test probes. The leads are 1.6m long. The shrouded banana plug connectors provide twice the standard number of contacts.

Circle (88) on Reply Card

Software system

Micro Design has introduced Ensemble, a software program designed for small field-service organizations. This scaled-down version of the Concert system features call handling and technician dispatch; invoicing of service calls; inventory of parts ordered and received with multi-location tracking; contract administration; report management; and a database for service engineer, customer, vendor, equipment and parts.

Circle (89) on Reply Card

Continued on page 59.

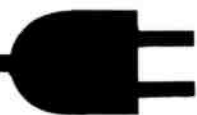

Plug in! To the NESDA system.

YOUR BUSINESS is in the world's fastest changing industry. If you're not careful, you could find your business in the dark.

But, you don't have to stay there.

Through a system of local, state, and regional groups, the **National Electronics Sales & Service Dealers Assn.** (NESDA) keeps members up-to-date with the fast pace of advancing technology while offering:

- ◆ Managerial and technical training.
- ◆ Business contacts.
- ◆ Technical and management certification.
- ◆ Information on new products.
- ◆ Legislative activities that affect the industry.

Don't be left in the dark. Let the NESDA system work FOR YOU!

For more information and an application, write to:
NESDA, 2708 W. Berry St., Ft. Worth, TX 76109; Ph (817) 921-9061

Name _____

Bus. Name _____

Address _____

State _____ Zip _____ Phone _____

Member of State Local Assn. _____

Do You Suffer From...

- High Prices
- Limited Selection
- Slow Delivery
- Unfriendly Service
- All of the above



MCM Electronics Brings Relief!

If you're tired of all the "headaches" that come from dealing with an electronics supplier that doesn't seem to understand your needs, it's time to pick up your phone and ask for a **FREE** copy of MCM's new catalog!

This 168-page "powerhouse" of electronic parts and components offers some of the best values in the industry on nearly 10,000 of the most commonly requested items.

You'll appreciate the friendly, personalized service provided by our courteous Sales Representatives and some of the most flexible payment terms in the industry. And you'll be pleased to learn that thanks to our huge inventory and state-of-the-art order entry system, your products can usually be on their way to you in 24 hours! So, get your copy today and get the relief you've been looking for. You won't be disappointed!

For your FREE copy, call TOLL-FREE! 1-800-543-4330

In Ohio, call 1-800-762-4315 In Alaska or Hawaii, call 1-800-858-1849



MCM ELECTRONICS

858 E. CONGRESS PARK DR.
CENTERVILLE, OH 45459-4072

A PREMIER Company

SOURCE NO. ES-34

Circle (22) on Reply Card

Q3208 HORIZONTAL OUTPUT

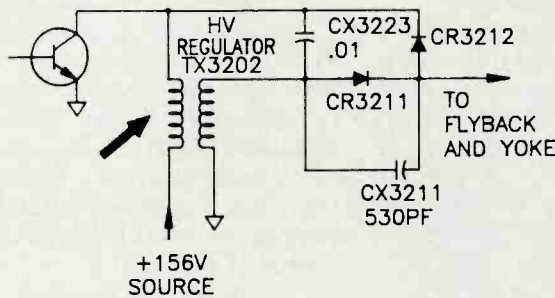

Chassis—Zenith Z1310A
PHOTOFACT—2265-2
Symptom—Intermittent high voltage or no HV.
Cure—Check for a bad connection at TX3202 (on heat sink). Resolder.

Q202 HORIZONTAL OUTPUT

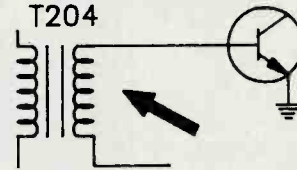

Chassis—Zenith 23HC45
PHOTOFACT—1637-2
Symptom—The HV is zero, and the Q202 has no drive. A new 9-90 module provided no improvement.
Cure—Check T204; replace it if a primary or secondary winding is open.

QX3326 HORIZONTAL OUTPUT

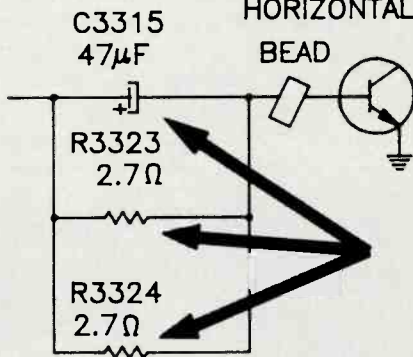

Chassis—Zenith SM1961W
PHOTOFACT—2021-2
Symptom—High voltage is excessive, and QX3326's life is too short.
Cure—Check C3315; replace it if it is leaky or has changed in capacitance. Also, check R3323 and R3324; replace if either has increased in resistance or opened.

T206 FLYBACK

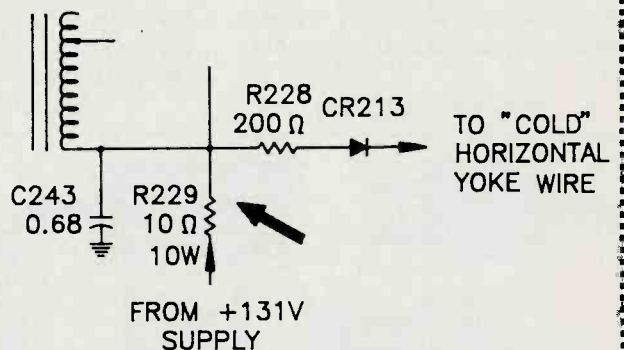

Chassis—Zenith 23HC45
PHOTOFACT—1637-2
Symptom—High voltage is zero; Q202 collector has 0Vdc.
Cure—Check R229; replace it if it is open or has increased in resistance.

Q202 HORIZONTAL OUTPUT

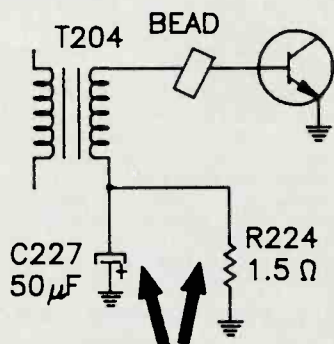

Chassis—Zenith 23HC45
PHOTOFACT—1637-2
Symptom—Narrow picture and low high voltage.
Cure—Check C227; replace it if it is leaky or open. Check R224; replace it if the resistance has changed.

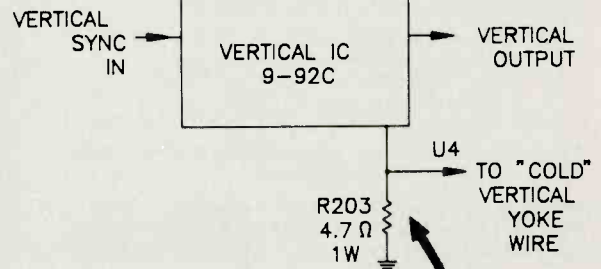

Chassis—Zenith 23HC45
PHOTOFACT—1637-2
Symptom—Insufficient height; a new 9-92C vertical module did not help.
Cure—Check R203; replace it if it has increased in resistance.

LCR meter

The LM22A hand-held LCR meter from *Beckman Industrial* measures capacitance (eight ranges, from 19pF to 1,999 μ F), inductance (seven ranges, from 19 μ H to 199.9H), resistance (seven ranges, from 1 Ω to 19.99M Ω) and dissipation. Basic accuracy for dissipation readings varies from 1% \pm 2 counts in the majority of user ranges, to 2% and 3% in the extreme low and high L and C ranges. The meter has a 9V battery and runs on ac power.

Circle (90) on Reply Card

Gold oscilloscope probe

The 4900 series gold oscilloscope probe from *Probe Master* includes 15 accessories with gold-plated probe tips and other interconnect points, which provide better contacts for low-level analog signals and high-speed digital data. A variety of models are available from 35MHz to 300MHz, with fixed or switched attenuation.

Circle (91) on Reply Card

Cleaning tools

The *Eraser Company* has introduced two cleaning tools. The CPL54 fiberglass rotary cleaning and burnishing brush has a 4-inch OD, a 1/2-inch face width and a 3/4-inch bore diameter. Several brushes may be stacked together on a spindle or mandrel to produce a wide-face brush.

The model ECT-1 portable, hand-held

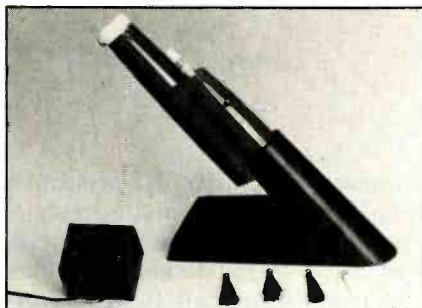

rotary cleaning tool comes with fiberglass, stainless steel, brass and nylon brushes.

Circle (92) on Reply Card

Break-out box

The model 232BOB break-out box from *B&B Electronics* allows you to test and rewire RS-232 interfaces. It opens signal lines, monitors signals and rewires lines using the jumpers included. The box incorporates nine 2-color LEDs that indicate high input, low signal or open line. It includes 24 switches that allow any RS-232 line to be opened, except for pin 1. Lines may be rewired to any configuration using the 20 jumper wires included.

Circle (93) on Reply Card

Line-voltage monitor

TEP has introduced the model 2200, a plug-in, 115V line-voltage monitor. By leaving the monitor plugged into any wall outlet, you can tell the exact line voltage and avoid using certain appliances during low-voltage periods. The monitor features a color-coded dial and records voltage from 95Vac to 135Vac.

Circle (94) on Reply Card

ES&T

**Learn
how to repair
VCRs...**

Read

Video Corner

each month

in ELECTRONIC

Servicing & Technology

Presenting an affordable Light Box System.

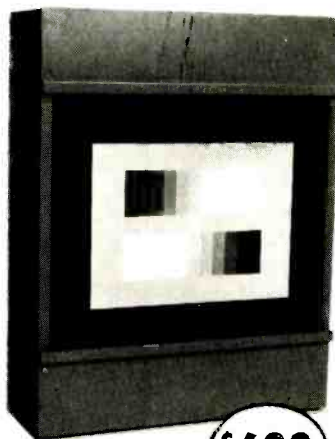

Model TR100 CB
Camera Light Box
with (2) transparencies

- (2) 3200° Kelvin Lamps (meets mfr. spec.)
- 1-year conditional guarantee
- Transparencies mounted in acrylic with optical scratch-resistant surface
- 11-step gray scale transparency
- 7-Bar color transparency

\$688

The method most manufacturers recommend

- All orders are shipped within 72 hours, U.P.S.

NUTRONIX (313) 939-2740

P.O. Box 77103 • Sterling Hts., MI 48077



Circle (23) on Reply Card

Setting up a shop log-- by computer

By Kirk Vistain

Computers—about half the techs I talk to are scared silly of them; the other half loves to mess with them. You can't get away from them. Like it or not, they are everywhere. That should be a clue. They are versatile, useful machines that can be put to work on the service bench as well as anywhere else.

There are many kinds of computers in the home entertainment electronics servicing industry. The vast majority are dedicated processors in VCRs, stereo receivers, cassette decks and other products. A large number also inhabit the inwards of test equipment, the most obvious example being the digital multimeter (DMM). They are programmed to do one particular task. Usually the program instructions are *burned* into the chip. Users cannot alter them. They are the "computers" that engender most of the negative feeling because they seem to make troubleshooting more difficult.

For example, manufacturers commonly upgrade the code (program instructions) in their microcontrollers during the production cycle of a particular model family. This means that early and late units may contain micros with different programs. The result may be that the same failure causes different symptoms in units whose only obvious difference is the serial number. This is not good for people who rely on symptomology to pinpoint defects, but it's something important for them to keep in mind.

The PC in the shop

Personal computers (PCs) are a different matter altogether. They are user-programmable. They are also very in-

expensive. An 8MHz, XT-compatible with 20Mbytes of hard-drive storage costs less than a typical oscilloscope, and much less than the virtually useless distortion analyzer most audio manufacturers require as part of your warranty authorization. Yet a PC, coupled with your own determination to keep track of repairs, tips, hints and bulletins, can boost your shop's productivity significantly.

Given the state of current technology, the PC works best as a database handler, a sort of substitute for an individual's memory. The concept of automated testing, at least in our industry, is impractical at the moment. Each manufacturer does things differently as far as board layout goes, so the machines used to test boards during mass production won't work for us. Most shops don't see enough of one given model or design to make a dedicated board tester practical.



I've often wanted to use a PC to monitor communications between the microcontroller and its various slaves and co-processors, to help isolate the defective section. Unfortunately, this usage seems impractical. Once again, there is little standardization among manufacturers. On top of that, it is virtually impossible to consistently get information such as signal protocol, the meaning of control codes, etc., out of manufacturers. This is true even if you happen to work for one of them.

Given these obstacles, the database route makes the most sense to me. It doesn't need to be anything complicated. Many good, inexpensive database programs are available for IBM PCs and clones. The newest ones are relatively easy to use. Certainly anyone with the skill to service CD players or VCRs should be able to set up a useful data file in a matter of hours. After that, you need to regularly enter repair results, preferably each day. You'll grumble at first as your fingers fumble over the keyboard, but after a while, you'll get used to it.

There have been attempts to put this kind of information on mainframe computers, accessible over telephone lines to anyone with a modem and a terminal. They haven't proven to be popular. First of all, starting the terminal, calling up and logging on are time consuming. Most people won't bother to do it regularly. This type of system might be more popular if it allowed mass download of all or part of the database to the user's computer, enabling easy local access in the future.

Setting up a shop database

By using information generated with-

Vistain is the audio consultant for ES&T.

in your own shop, if there's information about a fix you don't understand, you can always go back and get more details from them. You can also examine their testing techniques to further verify the information. Even a medium-size repair facility will generate much good data over a period of several months. If it services a wide spectrum of products, the resulting database will be fairly representative of field experience in general. A more specialized shop will end up with a more focused database, uncluttered by extraneous makes and models. Either way, the shop is preserving one of its most valuable, but intangible, assets—experience. When a technician leaves the establishment, a certain amount of his expertise will remain. If one's own memory is a bit clouded, as happens to us all from time to time, go over to the computer and punch in a make, model and problem. Five minutes

spent doing some research may salvage the repair (maybe the day) for you.

A repair database should contain at least the following items:

- make
- model
- symptom
- cure

A more involved database might add these:

- failure code
- repair code
- serial number (to track manufacturing run-dependent trouble)
- defective parts (greatly adds to complexity)
- originator (makes it easier to check validity and ask questions later)

The best way to handle implementing

the database would be as part of an integrated package that computerizes the shop's invoicing, accounting and parts inventory. It seems to me that any shop with more than three technicians ought to be giving some thought to a system like this.

Still, even a 1-man shop will benefit greatly from a properly maintained and used repair database. As I've mentioned before, a database is within the reach of anyone who can afford to be a warranty station. Give it some thought.

If any of you are interested, leave me a message on Compuserve (72356,1355) or Genie (K.VISTAIN). You can download and try out a simple, dedicated database handler I developed for IBM PCs and 100% compatibles.

By the way, if any of you have come up with ways to use the power of the PC for servicing, please write in and share them with us.

ES&T_{inc.}

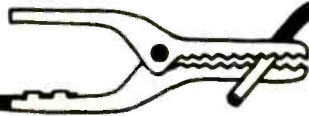

**1988
National Professional
Electronics Convention
and Trade Show**

August 1-6
Pheasant Run Resort
St. Charles, IL (Chicago area)

Increase your "current" business with:

- | | |
|------------------------------|---------------------------------------|
| Business Management Seminars | Technical Training in:
Digital VCR |
| Dealer/Manufacturer Meetings | Compact Discs |
| Exhibits | Personal Computers |
| Social Events | Digital-Audio Tapes |
| | Super VHS/S-Camcorders |

For information and registration, contact:

NPEC '88

2708 W. Berry St., Ft. Worth, TX 76109
817-921-9061



**BOARD REPAIR DEPOT
1 YEAR GUARANTEE!**

BOARD REPAIR:

Exceptional Quality & Reliability

* Advance Exchanges Available

* IBM PC, XT, AT

AT&T 6300

* COMPAQ

EPSON

TI

TESTING:

- 100% Functional test
- 12 hour Burn-in @ 115°F
- Outgoing final test and inspection

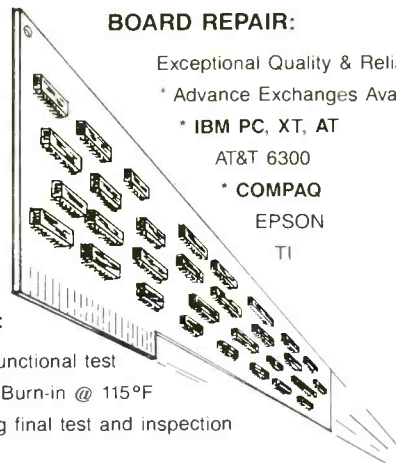

1-800-BOARDFX

D. S. Walker & Associates, Inc.
11210 Steeplecrest Suite #300 Houston, Texas 77065 (713) 890-2257

Circle (24) on Reply Card

Interfacing computers to the analog world--Part I

By Joseph J. Carr, CET

Editor's note: The next several installments of Computer Corner will discuss one of the most important aspects of the computer when used as a controller: how analog information from the outside world is converted to digital information that the computer can manipulate, and how the digital results of computer operations are converted back into analog information that can be used or interpreted by the world outside of the computer.

This first installment gives an overview of digital-to-analog conversion and its converse, analog-to-digital conversion.

Digital computers and the analog world speak fundamentally different electronic languages. Interfacing these two diverse worlds requires electronic translators to reconcile their language differences. In the next few installments of Computer Corner, we will examine the basic forms of data converter and real-world interfaces available to effect

Carr, an electronics engineer, is a frequent contributor to ES&T and has published a number of books on electronics.

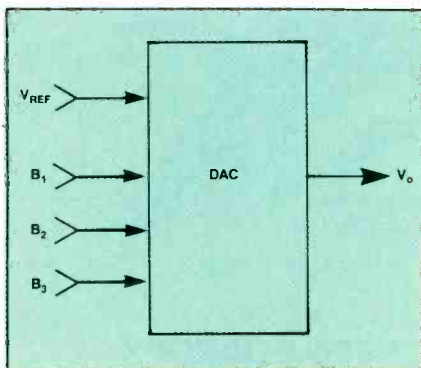

Figure 1. A DAC converts a binary digital word to an equivalent current or voltage. In this 3-bit DAC, the three parallel, digital input lines form a 3-bit binary number; each line represents one digit of the 3-bit (3-digit) number.

Table 1.
Binary numbers in a 3-bit system

Binary input	Decimal
000	0
001	1
010	2
011	3
100	4
101	5
110	6
111	7

that translation. These devices were traditionally used in instrumentation applications, but they now also turn up in microprocessor-controlled digital audio, VCR and professional video equipment, among other consumer and industrial applications. There is also at least one data converter in your digital multimeter (DMM), and there may be one in your oscilloscope, if it has numerical readout capability.

The data converter does one of two jobs: It either converts a binary digital word to an equivalent current or voltage, or it converts an analog current or voltage to an equivalent binary word. The former are called *digital-to-analog converters* (DACs); the latter are called *analog-to-digital converters* (A/D or ADC).

Digital to analog

Figure 1 shows a 3-bit DAC. (Real-world DACs are typically 6 to 32 bits, but a 3-bit version is used here to keep the discussion simple.) The three parallel digital input lines form a 3-bit binary number; each line represents one digit of the 3-bit (3-digit) number (or *word*, in digital terminology).

Each line can take only one of two

possible states: 0 or 1. In TTL-logic systems, the 0 is represented by 0V, while the 1 is represented by a positive voltage between +2.4V and +5V (if CMOS logic is used, other voltage combinations are possible). Table I shows all eight possible binary numbers in a 3-bit system, along with their decimal equivalents. Of course, longer binary words will count to higher decimal values. (For example, a 4-bit binary word counts to decimal 15.)

Figure 2 shows the transfer function (output vs. input) graph for a 3-bit DAC. The vertical axis shows the output voltage, while the horizontal axis shows the input binary words (with their decimal equivalents in parentheses for clarity). For simplicity's sake, assume a maximum V_o of +7V. Notice in Figure 2 that V_o increases a specific amount each time the input word increments one digit. This amount is called the 1-LSB voltage (LSB means the *least-significant bit*, or the rightmost digit in any number). This voltage is the minimum

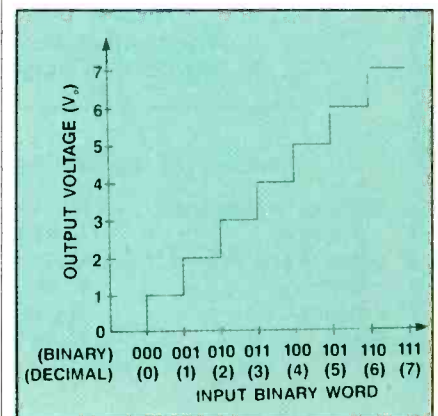

Figure 2. This transfer function (output vs. input) graph for a 3-bit DAC shows that V_o increases a specific amount each time the input word increments one digit. This amount, called the 1-LSB voltage, is the minimum amount that V_o changes when the least significant bit flips from 0 to 1 or from 1 to 0.

amount that V_o changes when the least significant bit flips from 0 to 1 or from 1 to 0.

The output of the DAC for any given input binary word is found from the following:

$$V_o = (V_{ref}) \times (A/2^N)$$

where V_o is the output voltage, V_{ref} is the reference input voltage, N is the number of bits in the binary input word (three in Figure 1), and A is the decimal value of the actual applied input word.

If V_{ref} is +8Vdc, then the maximum value of V_o (when $A=111=decimal\ 7$) is:

$$V_o = (+8Vdc) \times (7/2^3),$$

$$V_o = (+8Vdc) \times (7/8)$$

$$V_o = +7Vdc$$

The 1-LSB voltage (when $A=001=1$) in this case is 1V.

Analog to digital

The A/D converter (also called an ADC) does the opposite of the DAC: It converts an analog voltage or current to an equivalent binary word that can be input directly to a computer or other digital device. A block diagram is

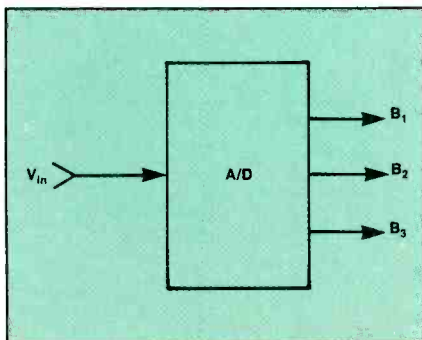

Figure 3. An ADC converts an analog voltage or current to an equivalent binary word that can be input directly to a computer or other digital device.

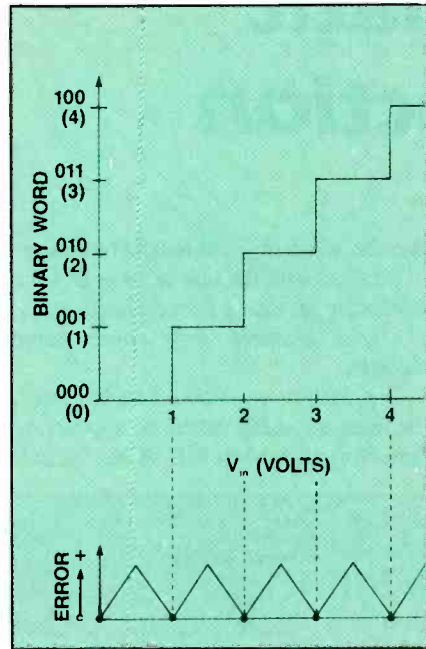

Figure 4. In analog-to-digital conversion, a quantization error exists because the binary word representing an analog voltage (or current) can take on only certain specific values even though the analog signal can take on any value between limits. This causes the staircase shape in Figure 4A. The amount of error slides up and down in a sawtooth form (Figure 4B) from zero to a maximum at the midpoints between voltage points.

shown in Figure 3. The transfer function is the same as in Figure 2 with vertical and horizontal axes swapped.

A fact of life when using ADCs is that a certain quantization error exists. Figure 4 shows this effect in detail. The quantization error exists because the binary word representing an analog voltage (or current) can take on only certain specific values even though the analog signal can take on any value between limits. This causes the staircase shape of Figure 4. For example, When $V_{in}=2V$, the output word is 010 (or 2 in decimal). The error in this case is zero. But at 1.51V and 2.49V input, the same 010 output exists, resulting in about a $\frac{1}{2}V$ error. The amount of error slides up and down in a sawtooth form from zero to a maximum at the midpoints between voltage points. Of course, the smaller the 1-LSB voltage, the smaller the quantization error.

Next month, we'll consider some electronic circuit schemes for achieving digital-to-analog conversion.

ES&T

INTRODUCTION TO VCR REPAIR ON VHS VIDEO TAPE

This new release by Ucando explains how the VCR works from the tuner to the RF modulator.

YOU WILL LEARN:

- How the chroma signal is processed
- How the luminance signal is processed
- How the audio signal is processed
- How the video drum servo works
- How the capstan servo works
- How the control head works
- How to clean the tape path
- Professional troubleshooting techniques

SAVE TIME AND MONEY

After viewing this program you will have a better understanding of how the VHS VCR functions. **To save time and money on your VCR repairs order your own VHS VCR tape now!** Simply call (513) 548-6113 and have your Master Card or Visa ready.

Price \$59.95

Please allow 2-4 weeks for delivery.

10 Day Money Back Guarantee!



VCR EDUCATIONAL PRODUCTS CO.
P.O. BOX 386
GREENVILLE, OHIO 45331

Circle (25) on Reply Card

ATTENTION TECHNICIANS

- ★ JOB OPENINGS
- ★ MONTHLY TECHNICAL TRAINING PROGRAM
- ★ BUSINESS MANAGEMENT TRAINING
- ★ LOW COST INSURANCE
- ★ CERTIFICATION
- ★ TECHNICAL SEMINARS

All of this in a nonprofit international association for technicians

FIND OUT MORE:



604 N. Jackson St.
Greencastle, IN 46135

The automatic search function

By the ES&T staff

Adapted from the GE technical Training Manual "VCRs and Video Cameras, 1984 Line."

Some of the more sophisticated VCRs have so many features, it's a wonder that the manufacturers can cram them all into such a small package. Of course, un-

less the servicing technician is intimately familiar with the unit or has all of the necessary servicing data on hand, some of these features may cause some chagrin.

One feature you should be aware of, the memory index function, appears on some top-of-the-line GE VCRs, includ-

ing the 1VCR4016. This feature makes it possible for the computer to automatically detect the starting position of a recording. Different from the conventional memory counter, this circuit uses the full erase head to record an index signal on the tape at intervals of one second near the part of the tape where the

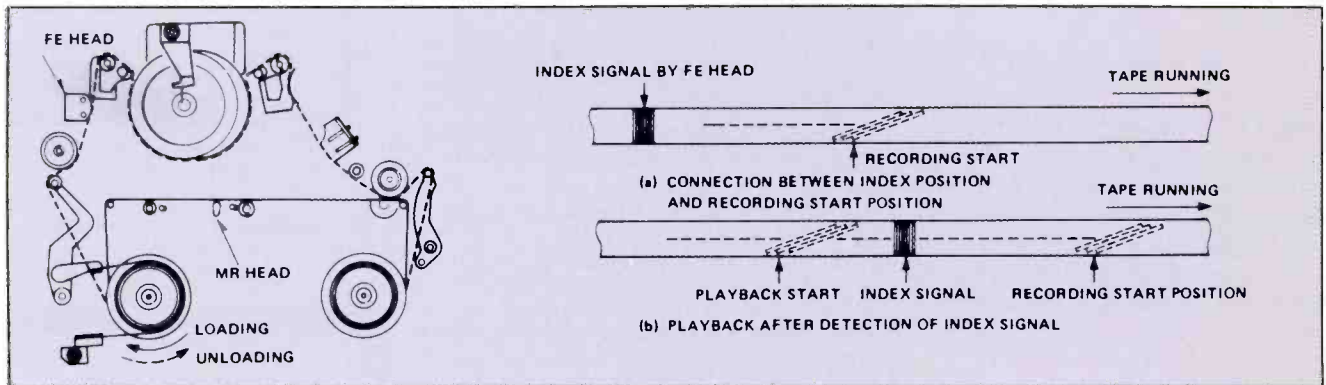

Figure 1. The full erase head records the index signals on the tape at intervals of one second. Because the full erase head is installed in a different position from the cylinder head, the index signals are recorded apart from the position where the recording of the video signal starts.

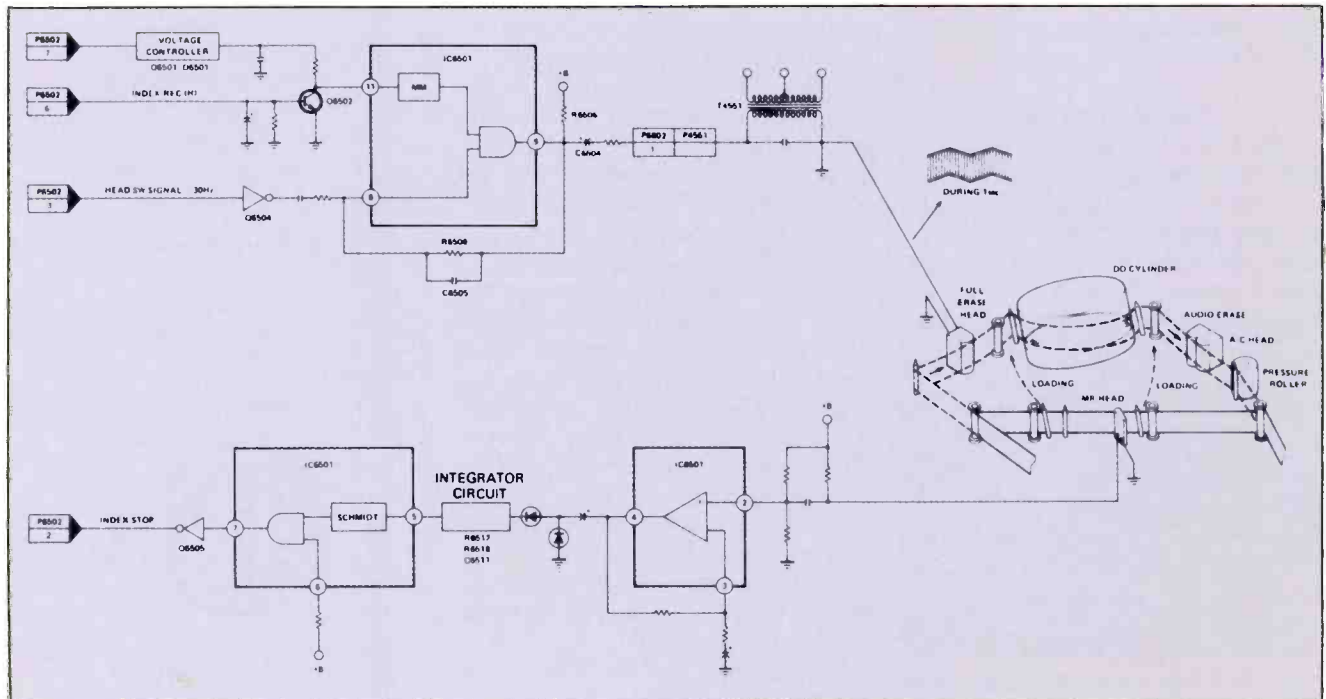

Figure 2. This schematic shows the circuitry used to apply the index signal to the full erase head and extract it from the tape with the special magnetic-resistance (MR) head.

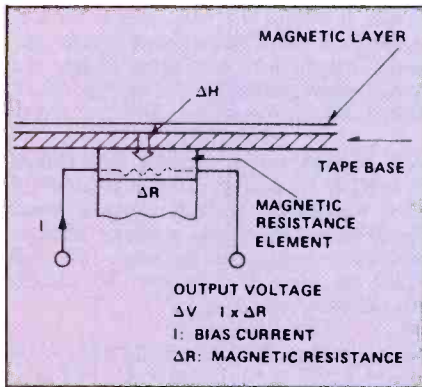

Figure 3. The magnetic resistance effect of the MR head uses the principle in which the magnetic resistivity (ΔR) reduces its effect in response to the intensity of the magnetism (ΔH) that is applied to the videotape.

program recording starts. This enables the circuit to memorize the starting position of the picture on the tape. A magnetic-resistance (MR) head detects the index signal during the fast-forward mode so that the unit automatically stops. In this way, the starting position of the picture on the tape is detected.

When the REC/PLAY button is pressed and loading is completed, the full erase head starts to record the index signals on the tape at intervals of one second each. The index signal is composed of a 30Hz ac bias, which does not adversely affect the video track on the tape. Because the full erase head is installed in a different position from the cylinder head, the index signals are recorded apart from the position where the recording of the video signal starts, as shown in Figure 1.

The circuitry used to apply the index signal to the full erase head and extract it from the tape with the special MR head is shown in Figure 2. Details of the MR head are shown in Figure 3. It uses the principle in which the magnetic resistivity (ΔR) reduces its effect in response to the intensity of the magnetism (ΔH) that is applied to the video tape. Thus, with a constant bias current flow (I) in the MR head, a constant out-

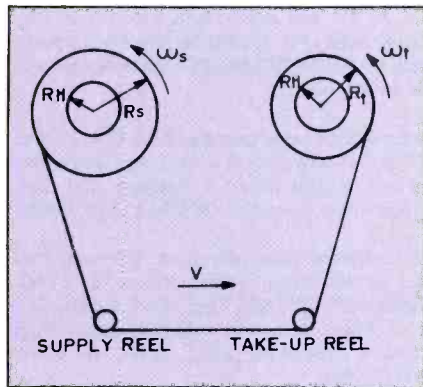

Figure 4. To compute the tape time remaining, an IC performs some complex calculations based on the parameters from the take-up and supply reels.

put voltage (ΔV), corresponding to the magnetic resistivity (ΔH), is obtained.

If that's not fancy enough for you, some of these units not only display the tape counter information, but also tell you in 5-minute intervals how much recording time is left on a tape (with an accuracy of plus or minus two minutes). The complex calculations required to determine this information are performed in a counter mode and remaining-tape time-display microprocessor, and are based on information sensed about the parameters listed in Table 1. (See Figure 4.)

Table 1.

Parameters for the time-remaining function

- Rh: Radius of the tape hub
- Rs: Radius of the supply reel
- Rt: Radius of the takeup reel
- Ws: Angular velocity of the supply reel
- Wt: Angular velocity of the takeup reel
- V: Tape speed
- L: Total tape length
- Ps: Number of supply reel rotations
- Pt: Number of takeup reel rotations



FREE

precision tool folder

small precision tools

for micro-electronics and miniature applications



minitool, inc.

Informative folder shows Minitool's line of precision miniature hand tools for laboratory and production tasks, fine assembly work, delicate deburring jobs, precise scribing and measurement, printed circuit artwork and repair.

- Hardened steel and carbide tool sets
- Technician tool sets
- Fine line diamond scribes
- Audible micro-electronic test equipment
- Electrical micro test probes with inter-changeable tips
- Unique precision pin vises
- Sapphire burnishing tools
- Micro surgical knives
- Zirconium ceramic scissors
- Ceramic tipped tweezers
- Direct-reading micro rulers

Send NOW for your FREE folder.

Minitool, Inc.
1334/F DELL AVENUE.
CAMPBELL, CA 95008
or call 408-374-1585

Circle (26) on Reply Card

**Technicians,
Get Serious
About Your
Profession**



Being a certified electronics technician lets people know that you are a professional in your field. It tells them that you are serious about your work and can perform up to CET standards.

Now you can order the "Study Guide for the Associate-Level CET Test" from the International Society of Certified Electronics Technicians. It includes material covering the most often missed questions on the Associate CET exam. 8 1/2" x 11", paperback, 60 pages.

For More Information Contact:

ISCET, 2708 W. Berry, Fort Worth, TX 76109; (817) 921-9101

NAME _____

ADDRESS _____

CITY _____ STATE _____

ZIP _____

_____ copies @ \$5 (+ \$1 postage.)

_____ send material about ISCET and becoming certified.

Readers' Exchange

Editor's Note: Readers' Exchange items are published in the order they are received. We are happy to offer this service at no charge to you, our readers, but we ask that:

- Items are typed (or legibly written).
- You include your name and address on the same page as your ad (envelopes and contents are often separated). Please also include your telephone number (specify if you don't want it published). Using your peel-off label is a good idea.
- You limit any ad to no more than three items. If space demands, ads will be edited to roughly four lines in the magazine.
- Mail to: Readers' Exchange, Electronic Servicing & Technology, P.O. Box 12901, Overland Park, KS 66212.

Please remember that **ES&T** is in production six weeks to two months *ahead* of publication date.

WANTED

Disk drive for a Timex Sinclair model 1000 or ZX#81 computer with cable or whatever they used to hook it to the computer—reasonable price. *Edward Barlow, Box 29, Tweed, Ontario, K0K3J0, Canada.*

Schematic for model 34 5-inch oscilloscope (in kit form) from DeVry Institute, Bell & Howell Schools. It has 5dePIF-crt on it. *Leonard Kocher, 827 Owl St., Norman, OK 73071.*

Schematic diagram and service manual for Pace Sidetalk-1000M AM/SSB CB transceiver. Will pay copying and mailing costs. *Barry Yee, B.Y. Electronics, 7762 Cumberland St., E. Burnaby, B.C. V3N 3Y3 Canada.*

100 time-delay relays, 0.1s to 5.0s, SPDT 10A contacts, 120Vac operation, octal base. *Ted Youngman, 2225 Vigo St., Lake Station, IN 46405.*

Admiral filament transformer, number A39842-AV for model 17C7988. *Valentine J. Ambrose, Roadrunner Electronics, P.O. Box 441, Wildomar, CA 92395; 714-677-6114.*

Sencore SC61 oscilloscope in good condition. *Holiday Video Repair, 500 C E. 10th St., Tracy, CA 95376; 209-836-0810.*

Schematic for Panasonic model RS-8185 stereo. Schematic no longer available. Photocopy is fine. *Ken Weber, 1249 Bellaire Blvd., Bellevue, NE 68005.*

Sencore PR57 Powerite. *Ed Herbert, 410 N. Third St., Minersville, PA 17954.*

Weller model WTCPL-WTCPN soldering station with controlled-output, in working condition or not (please state condition and cost); copy of schematic diagram for B&K model 1242 and 1245 color-bar generators—will pay for photocopy. *Jorge Alvarado, Urb. Rio Canas, Calle 12 L18, Ponce, PR 00731; 809-840-6898.*

Tektronix 321A scope and/or leather case for same. *Marv Lofness, 115 W. 20th Ave., Olympia, WA 98501; 206-357-8336.*

Obsolete tube chart for TV-10 tube tester; cord strain-relief installation tool; one-to-four section, 450V filter can capacitors. *Jim Farago, P.O. Box*

6313, Minneapolis, MN 55406.

Sequerra F <tuner, any condition, preferably with manual; schematic for Philco model 40-195 radio. *Mike Zuccaro, Voice & Video, 5038 Ruffner St., San Diego, CA; 619-560-1166 days, 619-271-8294 nights/weekends.*

Service info and/or schematic for Philco model 8300 scope/pre-amp, Crowncoorder CSC 9350 M AM/FM cassette unit, and General Sound model GE230 TV. Will pay for help, photocopies OK. *Leo E. Smith, P.O. Box 945 Vet Home Sect., Yountville, CA 94599; 707-944-4880, leave message with whoever answers.*

Schematic or service manual for a Conic model T7711A 13-inch color TV. Will copy and return or buy outright. *Robert J. Nathman, 240 Cambridge Circle, Corvallis, OR 97330; 503-752-4058.*

RCA 6DS4 nuvistors, new/used. Will trade from this partial listing: 6Y6G, 6L6 metal, 6L6G, 6146B, 6E5, 6U5, 1629 "eye" tubes, loctals, 5Z3, 80 rectifiers. Many new, others available. *Mark Skinner, 1420 Anna Road, Pekin, IL 61554; 309-353-1882.*

Schematic for a Sanyo Beta VCR, model 4020. Will gladly pay for a copy. *R. Stigney, 8400 Eastwood Road, Minneapolis, MN 55432; 612-786-3156.*

FOR SALE

HP 427A voltmeter, ac/dc, \$150; HeathKit im-25 VOM, \$20; Harrison Labs 810B power supply, solid-state, 0Vdc to 60Vdc, 0A to 7.5A, \$75; HP 710A power supply, 0Vdc to 400Vdc, 0.25A, \$20; all look/work well. Add postage. *J. Cruz, Box 3974, Langley Park, MD 20787.*

Power cords, used, good condition, 5-foot, 16-3 type SJ with HD reusable "U" ground plug, \$4 each postage-paid or 10 for \$30 postage-paid; "antique" pocket ammeter, 0A to 25A, pocket-watch style case, working condition, \$25; Military VTVM, ME-180/USM-116, no manual, used, repairable, \$30 plus shipping. *Donald H. Nash, 1444 Pulaski St., Port Charlotte, FL 33952; 813-629-3934.*

650 various Photofacts, #1 through #2318, complete lot \$0.50 each, FOB. Send SASE for electronic equipment. *Custom TV, 2962 Brockton Ave., Riverside, CA 92501; 714-686-2019.*

Sam's TV Photofacts, complete folders, below #1600; AR, MHF, TSM, TR, manuals. Send numbers you want and \$3 each. *Community TV, P.O. Box 199, Stony Point, NC 28678; 704-585-9968.*

Sam's Photofacts, #2194 through #2305. New, never been used, \$450 or best offer, plus shipping. *Darrell Feickert, 318 N. 17th St., Grand Forks, ND 58201; 701-772-8181, ext. 46, or 701-772-6928.*

Used TV and radio test equipment from \$5 to hundreds of dollars; electronic magazines from the 1950s to current, cheap; new and used tubes. Send \$1 for list or write what you are looking for and your price range. *Edward Barlow, Box 29, Tweed, Ontario K0K3J0, Canada.*

Sencore-SC61 waveform analyzer, VA62 video analyzer, VC63 VCR analyzer, NT64 NTSC pattern generator, PR57 Powerite isolation transformer, Tentelometer tape-tension gauge, Tentel VHS spindle-height gauge, Tentel head-protrusion gauge, Zenith torque gauge and VCR service manuals. Like new, whole package \$5,500. *Davin Helminen, 429 Hecla St., Laurium, MI 49913; 906-337-0335.*

TV receiving tubes, individually boxed, 475 total, asking \$125 or best offer; never-used Thordorson flyback, in original box with a number 308, asking \$12; B&K model 1827 6-digit, autoranging frequency counter with ac adapter, charger and 12-inch antenna, asking \$35. Add shipping. *Ronald Kolasa, 4942 E. Flower Ave., Mesa, AZ 85206.*

B&K 415 sweep marker generator, \$100; Hitachi V089 NTSC vector scope and Hitachi RM-099B NTSC waveform monitor, rack-mounted in Hitachi RM-099B rack, \$1,000 firm; logic scope 136 handheld battery dual-trace storage scope, \$200. *Bob Cahill, 91 Main St., Kingston, NH 03848; 603-642-8469, after 6 pm.*

Sam's Photofacts, #1000 through #2020 and #2299 through #2557, \$1.50 per folder plus UPS shipping. *Danny Rushing, Route 2, Box 386, Parsons, TN 38363; 901-847-6710 (day), 901-847-6258 (evening).*

Photofacts from #1 to #1,000, sell all for \$2.50 each, includes postage; assorted TR manuals from #6 to #194, 12 in all; assorted AR manuals from #20 to #196, 34 in all. Send SASE or call for list. *Joseph R. Marotta, 4227 N. 49th Ave., Phoenix, AZ 85031; 602-242-2004.*

Simpson Electric model 467 True RMS DMM, measures to 1,000Vdc, 750Vac, 2A ac-dc, 20M, includes leads and battery, \$100; Dumont model 1062 oscilloscope, 50MHz bandpass, dual vertical inputs, main and delay sweeps, \$495; Deihl model MARK III scanner, new, \$250. COD or add \$10 for insured UPS shipping. *Fred Jones, 407 Morningbird Court, Niceville, FL 32578; 904-678-1803.*

Sencore equipment: LC75 Z-meter, \$350; SC64 waveform, \$2,000; VA62 video, \$3,000; VC63, \$250; NT64, \$250. *Harmon Kenyon, Box 263 F-4, Salisbury M-H-P, Salisbury, MD 21801.*

Sencore model LC-53 Z-meter with leads, field calibrator, manual, SCR and triac tester, \$500 plus \$5 for shipping. *David A. Valencia, 7465 Hollister #141, Goleta, CA 93117.*

Sencore SC-61, new, \$2,700; TV tubes, boxed, lot of about 500, \$150; Sams facts, about 500, \$200. *Ed Hopfmann, P.O. Box 4, Berlin, MA 01503; 617-838-2561.*

B&K model 10778 TV analyst, \$150; B&K model 177 VTVM, \$40; Sencore model TC162 tube tester, \$40; Sencore model TF166 automatic transistor analyzer, \$50; Sams Quickfacts, 7 at \$5 each; Sams Photofacts (1,019 to 2,109), 95 sets at \$1 each; new RCA and Sylvania tubes; RCA, Zenith, Quasar and GE modules. Test equipment has all cables and manuals. Send SASE for list and prices. Shipping extra. *Duane Gage, 1188 S. Main St., Attleboro, MA 02703; 617-399-8592.*

Sams Quickfacts for RCA, GE, Sylvania, Pana-

sonic, Zenith (2 volumes), Philco and Magnavox, like new, all at half-price; Sencore Super Mack CRT tester-restorer with 22 sockets, excellent condition, \$275; B&K 1077B analyst, excellent condition, \$225. *Mike's Repair Service, P.O. Box 217, Aberdeen Proving Ground, MD 21005; 301-272-4984 (6-9 p.m., weekdays).*

B&K model 415 sweep/marker generator, new, with cables, connectors and manual. Cost \$525 new, buy at \$100. *J. Kapral, 101 Newberry Circle, Oak Ridge, TN 37830; 615-482-1482.*

B&K model 1251 NTSC color-bar generator, \$795; B&K model 1803 100MHz frequency counter, \$95; B&K model 1570A 80MHz, quad-trace scope, dual time base, \$895; B&K model 1560 60MHz, triple-trace scope, \$800. All like new. *Walter W. Dowdy, 500 C E. 10th St., Tracy, CA 95376; 209-836-0810.*

Sencore SC60 widebander, serial 3386249M, excellent condition, includes two probes, operator's and circuit description manuals. First money order for \$650 takes it. Shipping costs via UPS COD. *W.J. Uterback, 19777 Wheaton Drive, Cupertino, CA 95014; 408-253-7278.*

Code-A-Phone telephone answering machine with manual, in original carton, \$50 plus shipping; 600 new, standard brand tubes in factory cartons, 90% off list price; radio and TV parts; text books, service manuals. Send large SASE for list. *M.*

Seligsohn, 1455 55th St., Brooklyn, NY 11219.

B&K 2040 CB signal generator, \$250; B&K 1040 CB Servicemaster. \$195; B&K 1077B TV analyst, \$185; B&K 415 sweep marker generator, \$175; Eico model 1030 regulated power supply, 0-400Vdc, \$75; two Simpson 260 meters (need minor repair), \$25 each; Viz WV-26A isolation transformer, \$35; Calrad Variac, 0-130VAC, \$45. All in excellent condition. All B&K equipment like new, with cables and manuals. Cash or money order only. Will ship UPS. No collect calls. *Gordon E. Lane, 239 Jacksonian Dr., Hermitage, TN 37076; 615-889-6195.*

Vacuum tube grab box: about 20 new, in box (IG3GT, 12FX5, 4JC6, etc.); about 75 new and used, no boxes. \$15 plus shipping and handling. *Larry N. Jackson, Route 2, Box 299J, Hamptonville, NC 27020; 919-468-2758.*

Castle tuner subber Mark 4, \$35; HV probe (Heathkit), 40kV, \$20; Sams Photofacts and Quickfacts (send SASE for list). *Ernest F. Meade, 502 First Ave., West Logan, WY 25601; 304-752-0010.*

Sencore LC-53 Z-meter, factory refurb., #600; B&K 1403A 5MHz, 3-inch, single-trace scope, with probe, \$195; Simpson 461 DMM w/RF probe, case, \$145; Sigma AF250L AM/FM analyzer (modulation/deviation meter), \$95; CPI FC-70 70MHz freq. counter, \$75; B&K 5208B

transistor tester, \$195; HP 200CD audio signal generator, \$120. Send legal-sized SASE for more info. *J.C. Estabrook, P.O. Box 5476, Cheyenne, WY 82003; 307-635-0220.*

Fluke #37 bench-type DMM, used only once, \$200 plus shipping; B&K model 1805 80MHz, multifunction freq. counter, \$200; FE-20, excellent condition, factory calibrated, \$75. Include boxes, manuals and warranty cards. *Stanley Todorow, G8468 Belle Bluff Drive, Grand Blanc, MI 48439-8919; 313-695-0271.*

Sencore VA48 analyzer with TR219 isolation transformer, manuals and probes, \$800 or best offer; complete set of Tentel VCR alignment gauges, never used, \$1,200 or best offer; Zenith, RCA, Magnavox, Philco and Sylvania VCR service literature, send SASE for list. Add shipping. *John Dews, P.O. Box 20726, Montgomery, AL 36116; 205-288-8479.*

Sound/Technology 1000A generator and 1700B distortion analyzer with options; two RCA TV chassis test jigs with adaptors. *Electronic Services; 219-484-3326.*

Sencore VA-62 video analyzer with VC-63 accessory, test leads, manuals and probes, including TP212 HV probe. Perfect condition, \$2,900, or will trade for Sencore SC-61 scope. *Michael E. Carter, NCS Box 7, FPO NY 09539.*



Classified

Advertising rates in the Classified Section are \$1.55 per word, each insertion, and must be accompanied by payment to insure publication.

Each Initial or abbreviation counts as a full word.

Minimum classified charge \$30.00.

For ads on which replies are sent to us for forwarding (blind ads), there is an additional charge of \$35.00 per insertion to cover department number, processing of replies, and mailing costs.

Classified columns are not open to advertising of any products regularly produced by manufacturers unless used and no longer owned by the manufacturer of distributor.

FOR SALE

TV TOUGH DOGS: 300 symptoms and cures. Send \$7.95 to DAVIS TV, 11772 Old Fashion Way, Garden Grove, CA 92640. 10-87-tfn

AUTOMOBILE RADIO, TAPE and amplifier repairs most manufactures. Quick turn around time. Send your units to us at, Laran Auto Electronics, 188 W. Lincoln Avenue, Mount Vernon, New York 10550. Inquiries: P.O. Box 466, Bronx, New York 10475. 914-664-8025, 800-223-8314. 5-88-tfn

INTEGRATED CIRCUITS-Lowest prices on Admiral, GE, NAP, Philco, RCA, Sears, Sylvania and Zenith types. Write P.E.C. Box 894 Union, NJ 07083 03-88-6t

VHS-VCR REPAIR SOLUTIONS VOLUMES I, II, III. Each contains 150 symptoms and cures, cross reference chart, free assistance. Each \$11.95, any two \$19.95, all \$29.95. Eagle Electronics, 52053 Locks Lane, Granger, IN 46530. 5-88-tfn

"UNCLE JON'S SEMICONDUCTOR CRISS-CROSS" 1000's of TV, VCR, and audio ICs and transistors cross referenced FROM General Purpose Replacement Part Numbers (ECG**, NTE**, and others) TO RCA, Zenith, GE and many Japanese part numbers. If you need a type 712 TV sound IF/Detector, don't order an expensive replacement, check your stock for EP84x73(GE), HA1124(Hitachi), or AN240(Matshushita). Pays for itself the first time you use it. \$8.95 Ea. Uncle Jon's Video Service Co., 12871 Briarwest Circle, Houston, Texas 77077. (**Phillips ECG, **NTE). 4-88-3t

VIDEO TUNE-UP disk converts C64 computer into video analyzer. All video patterns including bar-sweep \$39.95. SOLAS, Box 665, Springhouse, PA 19477. (215) 723-4597. 6-88-1t

TV/VCR "Tuff Tips" listed by mfg. and model. 1st or second edition. 200 tips per edition. \$10.95, both editions \$19.95. TV Tips only. 1st or 2nd edition \$5.95, both editions \$10.95. VCR Tips only. 1st or 2nd edition. \$6.95, both editions \$12.95. TECH CURES, 4825 Fredericksburg Road, San Antonio, Texas 78229 6-88-tfn

TV/VCR Failure Histories-Multiple cures for most problem areas. Send \$6.95 with mfg. and model number to TECH CURES, 4825 Fredericksburg Road, San Antonio, Texas 78229. Money will be refunded with free sample, if model is not on database. 6-88-tfn

VCR CROSS-REFERENCE listing for the following electronically-similar manufacturers: RCA, GE, Sylvania, Panasonic, Quasar, Magnavox, Philco, and J.C. Penney. Send \$13.95 to TECH CURES, 4825 Fredericksburg Road, San Antonio, Texas 78229 6-88-tfn

PHOTOFACTS: Individual folders #1400 \$3.00. Above #1400 \$5.00. Sent same day first-class post-paid. Loeb, 414 Chestnut Lane, East Meadow, NY 11554. 6-88-3t

SENCORE FC 71, \$600.00. VA48 \$600.00. CB49. B&K 415 Sweep analyst telematic VHF/UHF subber & over 800 tubes. Best offer. Ron MacKenzie. 41 Wheelwright Ln. Levittown NY (516) 579-8546. 6-88-1t

SONY-TRINITRON Rebuilt Picture Tubes are now available. All tubes shipped U.P.S. No Charge. We buy all Sony duds. Rochester Kinescope. 716-235-0750. 11-87-tfn

TV TROUBLESHOOTING: 160 Problems-Solutions on models/chassis in service today. Nothing old listed. Complete narrative on each solution. Also, 15 effective steps to easier repairs. \$12.00. Jones, Box 702, Niceville, FL 32578. 2-88-6t

BUSINESS OPPORTUNITIES

ORLANDO, FLORIDA-TV rentals & service well established in rapidly growing area. great profits. Ideal for technician with \$22,000. Call owner: 407-275-9543. 6-88-1t

OWNER RETIRING electronics and home appliance business for sale with repair parts and equipment, trade fixtures, office equipment, delivery van plus trade in inventory. Five year lease of down town store available in north central Wisconsin. Subject to inventory on day of sale. \$25,900.00. Woller Realty, 102 S. Court St. Merrill, WI 54452. Phone 715-536-5725 6-88-2t

BUSINESS OPPORTUNITY: 12 years established television sales and service. Service literature, parts, equipment, building, van, rural location. Will assist new owner, consider partial financing. 1-816-776-6064. 6-88-1t

TV "TECH'S" DREAM

TEST & RESTORE EVERY CRT on the market.... without every buying another adaptor socket for your CRT tester. Fits ALL makes & models. MONEY BACK GUARANTEE. Over 12,000 sold. Complete Patented Kit, with Sockets & Setup Book.... Only \$63.95 ppd. A one-time investment for life!! Visa/MC/COD's/Checks.
FREE CALL 1-800-331-9658
DANDY MFG. CO.
 2323 Gibson Street Muskogee, OK 74403

Circle (27) on Reply Card



HAND REMOTE REPAIR

LA GUARDIA ENT

5882 Rich Hill Way
 Yorba Linda, CA 92686
 (714) 579-1276

- Call for pricing
- 24 hr. turnaround time
- Return freight pre-paid

90 Day Warranty New Battery Included

Circle (28) on Reply Card



"Tech's Guide To Pricing"

updated new 5th edition... a framework for setting rates that apply to Hi-Tech products... a formula that guarantees SUCCESS!

Call Toll Free for details **1-800-228-4338** 8/5 CST

Circle (29) on Reply Card

Picture Tubes

American-Foreign-Monitor

Price covers most 13" to 25" picture tubes. CALL US for a PRICE QUOTE. **\$49.95**

• Quality Handcrafted • Fast Exchange/Repair • 1-Yr. Warranty • Check our SONY PRICES! • Use your Master Card/Visa/COD/Check*** Call 800-333-4872

TSC/CENTEC 303 N. Curry Pike, Bloomington, IN 47401 Telephone 812-334-0411

Over 1000 Types

Circle (30) on Reply Card

MOVING?

If you're planning a move in the near future, don't risk missing an issue of Electronic Servicing & Technology. Please give us 6-8 weeks notice if you're planning on changing your address. Just write in your new address below and mail this coupon, WITH YOUR SUBSCRIPTION MAILING LABEL, to:

ELECTRONIC

Servicing & Technology

Subscriber Services

P. O. Box 12901

Overland Park, KS 66212

Name _____

Address _____

City _____

State _____ Zip _____

Ad Index/Hotline

Company	Page Number	Reader Service Number	Advertiser Hotline
American Reliance	55	21	800/654-9838
Amprobe Instruments	7	7	516/593-5600
Beckman Industrial Corp.	IFC	1	619/495-3200
C + S Sales	53	11	800/292-7711
Chemtronics, Inc.	1	3	800/645-5244
Cooper Group	51	18	919/362-7510
Dandy Mfg. Co.	68	27	800/331-9658
Digikey	23	9	800/344-4539
ETA	63		
Fluke, John Mfg. Co., Inc.	5,27,41	6,15,10	800/227-3800
Genstar Rental Electronics	47	34	
IS CET	65		
Joseph Electronics	19	16	800/323-5925
Kelvin Electronics	45	12	800/645-9212
Laguardia Enterprises	68	28	714/579-1276
Leader Instrument Corp.	3	4,5	800/645-5104
MCM Electronics	57	22	800/543-4330
Mini-Tool	65	26	408/374-1585
NESDA	57,61		
Panavise Products Inc.	43	17	213/595-7621
Parts Express Int'l Inc.	49	19	513/222-0173
Philips ECG	10-11	8	
Projector Recorder Belt Corp.	55	20	800/558-9572
Sencore, Inc.	IBC	2	800/843-3338
Sperry Tech, Inc.	68	29	800/228-4338
Tektronix, Inc.	13,15, 17	31,32,33	800/433-2323
Tektronix, Inc.	16A-16B		800/433-2323
Tronix, Inc.	59	23	313/939-4710
TSC Service Corp.	68	30	800/333-4872
U.S. Instrument Rentals	25	14	800/824-2873
U-CAN-DO VCR Educational Products Co.	63	25	513/548-6113
Walker, D.S. & Associates	61	24	713/890-2257
Zenith	BAC		

Use ES&T classified ads

ELECTRONIC SERVICING & TECHNOLOGY Volume 8, No. 6 (USPS 462-050) is published monthly by Intertec Publishing Corp., 9221 Quivira Road, P.O. Box 12901, Overland Park, KS 66212. Second Class Postage paid at Shawnee Mission, KS, and additional mailing offices. POSTMASTER: Send address changes to ELECTRONIC SERVICING & TECHNOLOGY, P.O. Box 12952, Overland Park, KS 66212-9981.

ADVERTISING SALES OFFICES

ELECTRONIC

Servicing & Technology

KANSAS CITY, MISSOURI

Greg Garrison, Sales Manager

P.O. Box 12901

Overland Park, KS 66212

Phone: (913) 888-4664

Fax: (913) 888-7243

Telex: 42-4156 INTERTEC OLPK

OXFORD, ENGLAND

Nicholas McGeachin

Roseleigh House, New Street

Deddington, Oxford OX5 4SP

Phone: (0869) 38794

Telefax: (0869) 38040

Telex: 837469 BES G

TOKYO, JAPAN

Haruki Hirayama,

EMS, Inc.

Sagami Bldg., 4-2-21, Shinjuku,

Shinjuku-ku, Tokyo 160, Japan

(03) 350-5666

Telex: 2322520 EMSIN CJ

Cable: EMSINCPERIOD

FREWVILLE, SOUTH AUSTRALIA

John Williamson

Hastwell, Williamson, Rep. Pty. Ltd.

109 Conyngham Street

Frewville 5063

South Australia

Phone: 799-522

FAX: 08 79 9735

Telex: AA87113 HANDM

With Just One Probe Hookup You Can Confidently Analyze Any Waveform To 100 MHz, 10 Times Faster, 10 Times More Accurately, Absolutely Error Free, Guaranteed Or Your Money Back . . .

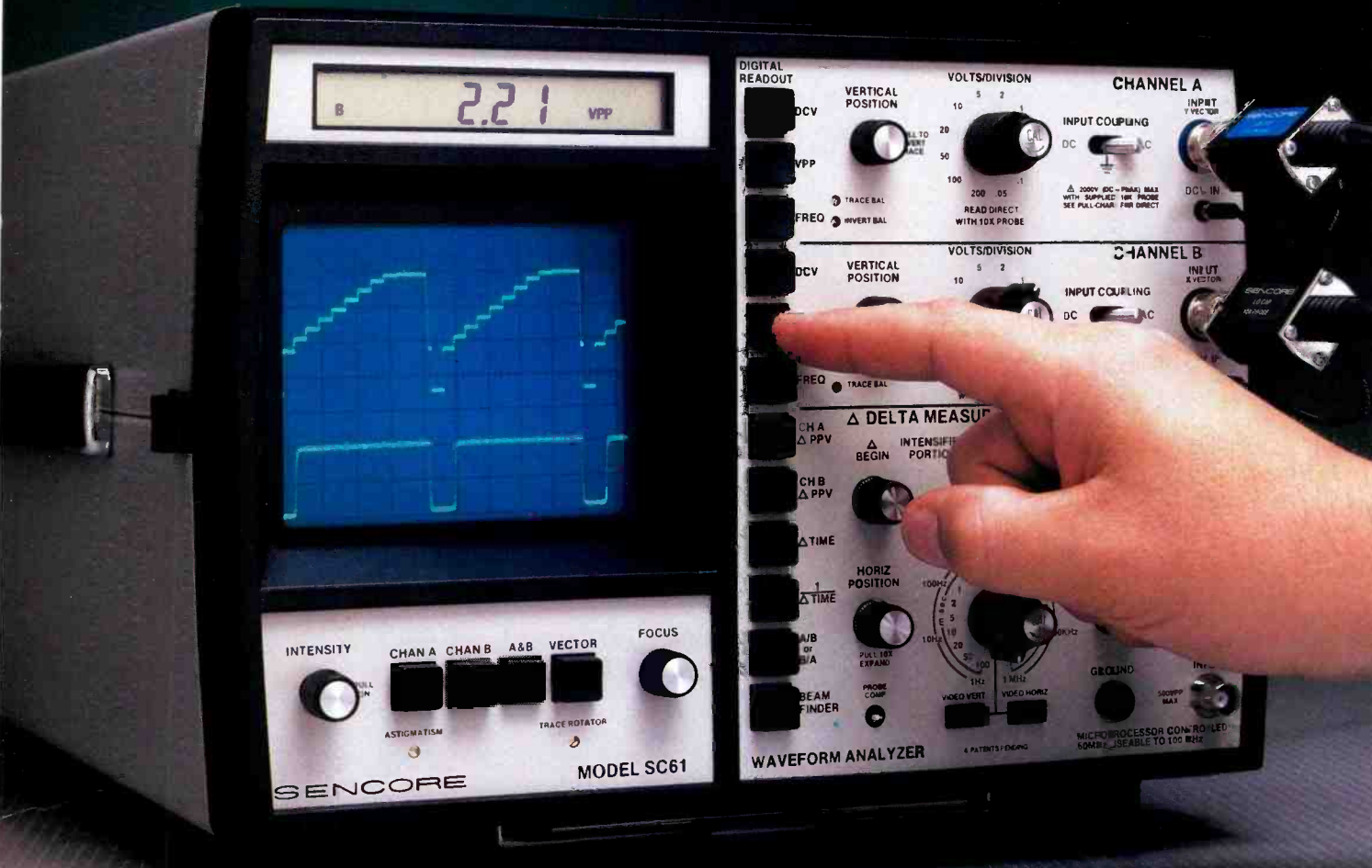

With The SC61 Waveform Analyzer
\$3,295.00 PATENTED

Promises of increased productivity from other oscilloscopes fade fast when compared to the speed and accuracy of the SC61. Eliminate the confusing menus, cursors and complexity of regular oscilloscopes at the push of a button. Here's what the SC61 does for you:

Analyze Waveforms Easily

- Accurate Waveform Display - 60 MHz Bandwidth (usable To 100 MHz) To Test The Latest Digital Circuits.
- Rock-Solid Sync - ECL Logic Circuits And Differential Amplifiers Give Fiddle Free Operation.
- Four Times The Measuring Range - Measure From 5 mV To 2000 Volts (3000 Volts Protection) For Expanded Signal Handling.

Autotracking™ Digital Readings Analyze The Whole Signal

- Autoranging DC Volts Through Single Probe, Even With AC Coupled.
- Automatic Peak-To-Peak Volts - Even If Variable Controls "Out Of Cal".
- Automatic Frequency Measurements Without Sensitivity Adjustment Or Range Switching.

Circle (2) on Reply Card

Digital Delta Tests Analyze Any Part Of The Signal.

- Delta Peak-To-Peak Volts - Peak-To-Peak Volts Of Any Part Of The Signal.
- Delta Time For Any Time Reading - Including Delay Between Traces
- 1/Delta Time - Frequency Of Part Of The Signal - Finds Sources Of Interference Or Ringing.

Frequency Ratio Test - Tests Multiplier And Divider Circuits

Easy To Use - Human Engineered Controls And Virtually No Graticule Counting Or Calculations

The SC61 is designed to give you the measurements you need - fast. We make one claim:

"Try the SC61 on your bench for 30 days. If it doesn't cut your present scope time in half, send it back for a complete refund, no questions asked."

Try the SC61 for 30 days, and discover true troubleshooting speed.

Call 1-800-843-3338
In Canada Call 1-800-851-8866

See us at the CES Show In Chicago, June 4-7, Booth #2266, E. McCormick Building

SENCORE

**For your own reputation
and in your customers' best interest
always insist on**

Genuine Zenith

Remanufactured Replacement Parts

Reconditioned and Serviced for Reliability

by Zenith People

as Knowledgeable and Dedicated as

Those Who Made the Originals!

One of the easiest, fastest, and surest ways for you to preserve the pedigree and maintain the quality of the Zenith products you service is with genuine Zenith replacement parts.

And at no time is this more critical than when you replace the more sophisticated components like modules, tuners, channel selectors and sub-assemblies.

Your participating Zenith parts distributor will supply you with a replacement remanufactured, reconditioned and serviced for reliability by Zenith people as dedicated and knowledgeable as those who made the original.

Equally important, the replacement module or sub-assembly you receive in exchange from your Zenith parts distributor

will most likely incorporate any Zenith factory-made modifications in effect at the time of remanufacture.

And nowhere else but in a participating Zenith parts distributor's Exchange Program can you get assurance that a replacement incorporates Zenith factory up-dates!

To learn the location of the Zenith R&R Exchange Counter in your area, write on your company letterhead and we will help you locate one that's nearby.

Risking an exchange for a Zenith replacement anywhere else doesn't make sense. Not when factory-fresh replacement modules and sub-assemblies are so readily available thru a Zenith parts distributor's Exchange Program! Write now!

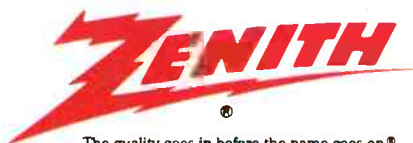

The quality goes in before the name goes on.®

Zenith Service, Parts & Accessories • 11000 Seymour Avenue, Franklin Park, Illinois 60131 • A Division of Zenith Electronics Corporation